

# BEF Infantry Brigade

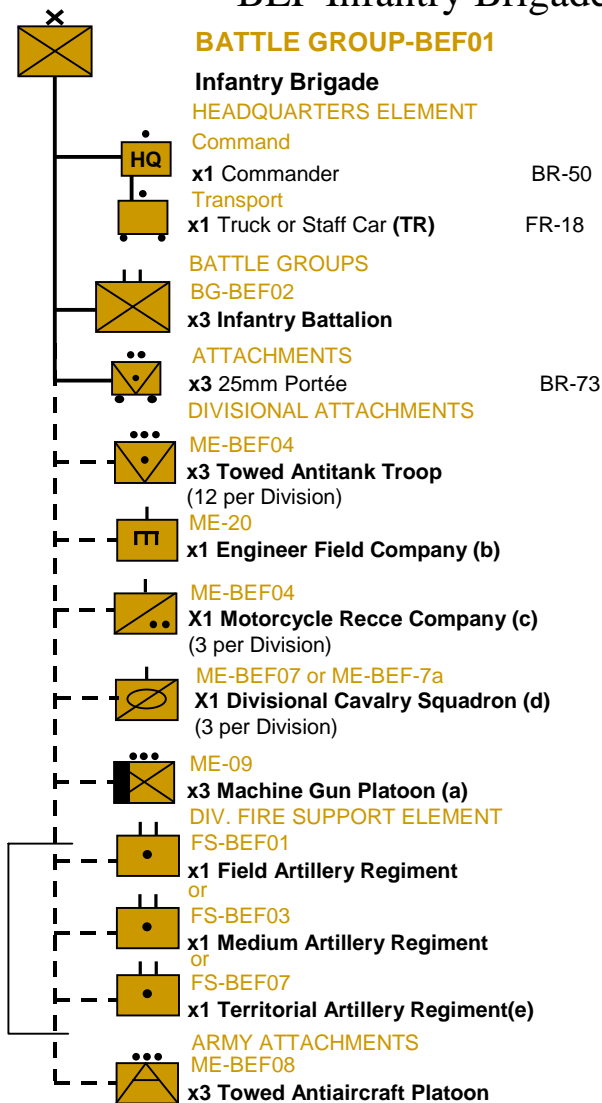

## Note TR – Soft Transport

This note can apply to any of the BEF formations.

The BEF was nominally the only fully motorized army at the time. While this is technically true, the reality is less rosy. To achieve the 100% mechanisation of the BEF, the Army requisitioned almost anything with wheels and a motor. The result was that everything should be allowed to travel in trucks and lorries. Battalion HQs should have a staff car or something similar. Montgomery commanded such a unit in 1940, and reported afterwards that it was a logistical nightmare, the requisitioned trucks had not been well maintained in civilian life, and therefore suffered massive problems with breakdowns and getting spares.

As such, the transport allocated to the BEF units could reasonably any of the trucks or other soft transport available, such as the French Trucks and motorcycles. FR-18, FR-19, FR-20, FR-21 as well as the British BR-43 or BR-44.

Feel free to model the breakdown problems in a scenario by having fewer than the full number of motorized transport units available, especially for scenarios set after the front had collapsed..

- (a) May substitute soft transport (see Note TR) for carrier.
- (b) Substitute ATR (BR-76) for PIAT in ME-20. Also, Note TR applies to the engineer transport.
- (c) See BG-BEF04 This was not usually an infantry division asset and will rarely appear. The divisional motor cycle battalion was restricted to Motor Divisions. For example 1 Queen Victoria Rifles were warned for duty as such as divisional 'cavalry' for 1 London Division on 11 May 1940 before going to Calais with 30 Infantry Brigade. There were two Motor Divisions and therefore theoretically motorcycle battalions in the BEF: 23 Division (which was organized for labour duties so the assets of 8 Northumberland Fusiliers may not have been present) and 50 Division (4 Northumberland Fusiliers which took part in the Arras counter-attack).
- (d) See BG-BEF07. In France the Divisional Cavalry Regiments were removed from the divisions in early 1940 and either became Army troops or formed Light Armoured Reconnaissance Brigades so this attachment is theoretical but also rare.
- (e) Front Line Territorial Divisions were almost identical to other infantry divisions, but had different artillery support.

# BEF Infantry Battalion and MEs

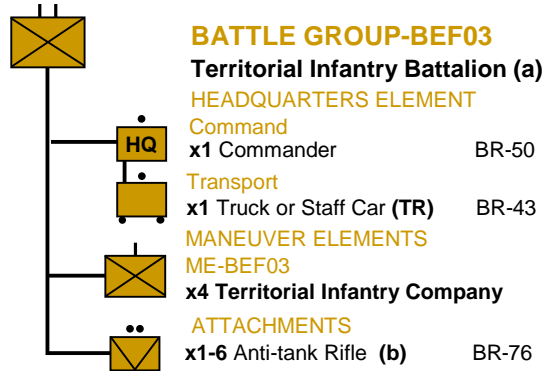
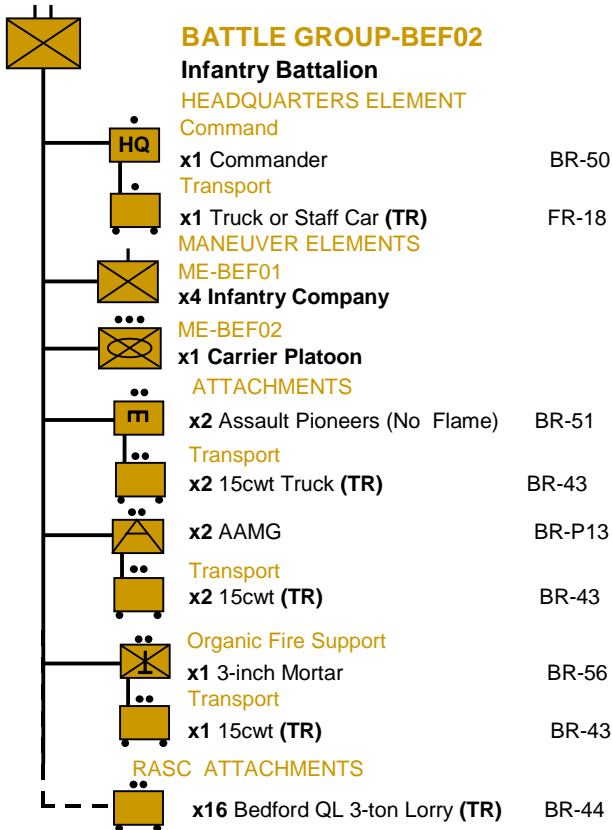

(a) These troops do not represent first line territorial divisions which should (aside from artillery) be treated as standard units. It represents those divisions dispatched to France as labour units to finish their training (12, 23, 46 Divisions) and existing line of communication and pioneer troops that were unexpectedly caught up in the fighting.

(b) In theory the battalion had 18 AT rifles although there are references to having to scrounge them.

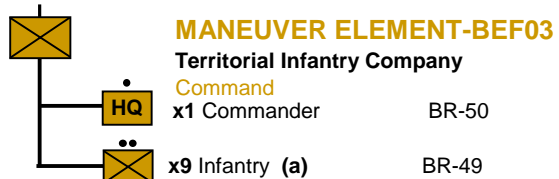
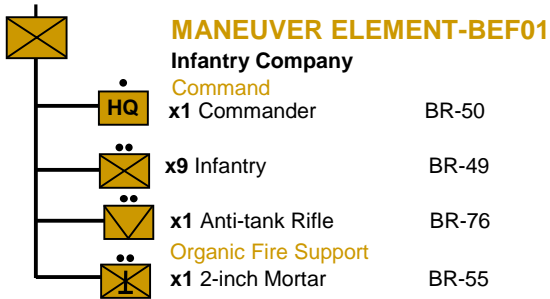

(a) Pioneer and rear echelon troops were short of Bren LMG. You may use the Russian values on the Russian rifle Infantry card (RU-17) for these troops.

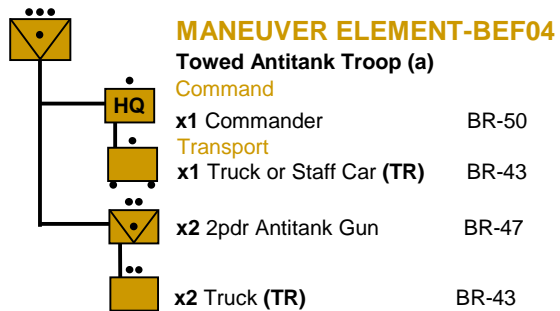
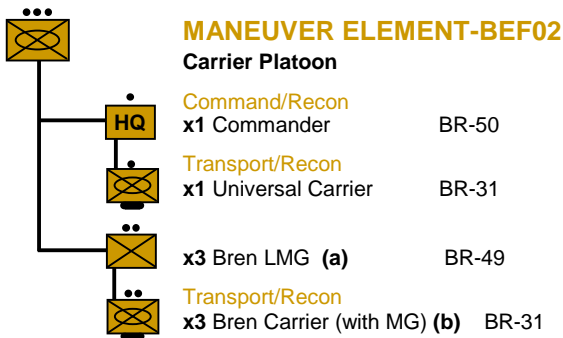

(a) May dismount as:  
 Bren Light Machine Gun BR-53  
 or Boys ATR (1 per platoon) BR-76  
 or 2-inch Mortar (1 per platoon) BR-55  
 – note that sources conflict over whether 2" was available

(b) Carriers fire without machine gun weapon rating when passengers dismount.

(a) The towed antitank troop may also operate as separate unit attachments to a maneuver element or headquarters element.

# BEF Inf. Div. Support Elements

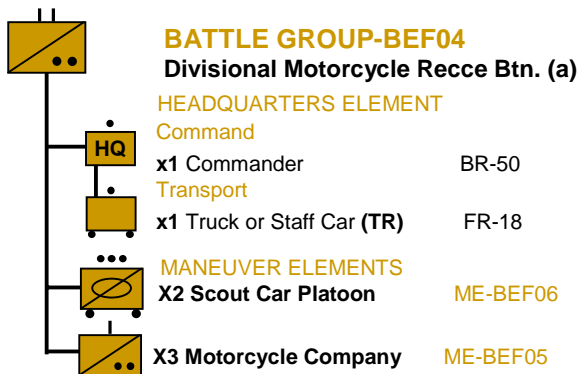

(a) Elements may operate independently and be attached to formations within the division.

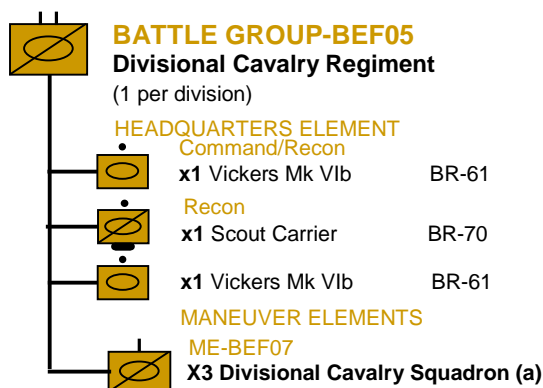

(a) Cavalry squadrons may individually attach to brigades

Note-only one Divisional Cavalry regiment would be present in an infantry division. The Divisional Cavalry Regiment in the BEF was generally withdrawn prior to 10 May 1940 and either held as Army troops or formed into Light Armoured Reconnaissance Brigades. On formation 1st, 3rd, 4th, 48th and 51st seem to have had Divisional Cavalry Regiments, all of which were withdrawn at the end of March 1940 (although 1st Lothians were reattached to 51st (Highland) from GHQ troops possibly because of their independent operations).



(a) 2" mortars were not part of the 1939 establishment, but may have been present. If not, drop one MC as well.

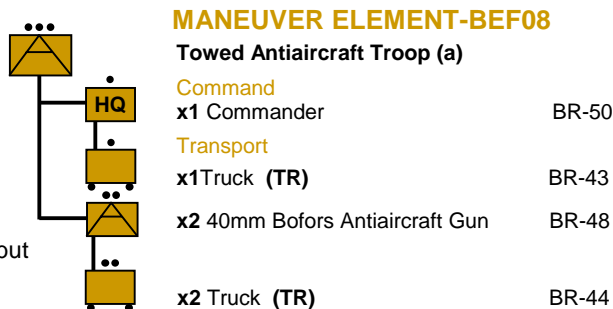

(a) The guns in the towed antiaircraft troop may also operate as separate unit attachments to a maneuver element or headquarters element.

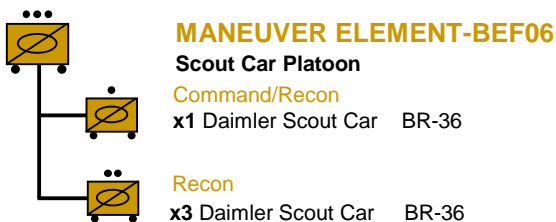

# BEF Army Tank Battalions

The BEF fielded 2 tank Battalions at Army Level, (as part of the 1<sup>st</sup> Army Tank Brigade), the 4<sup>th</sup> and 7<sup>th</sup> Battalions of the RTR (Royal Tank Regiment). These were among the more famous of the British formations as they took part in the armoured counterattack at ARRAS, which caused the Germans a momentary check to their headlong rush to the sea. The 4RTR was equipped with A11 Matilda I (BR-68) while 7RTR had a mix of A11s and A12 Matilda II (BR-69). The A11 Matilda I came in two varieties, those with .303 machine guns and those with a heavy machine gun (.50 cal). There is mention of A11s with .50 cal guns as opposed to the standard .303s in HQs, which we are assuming to be section HQs. The theoretical full strength organization is:

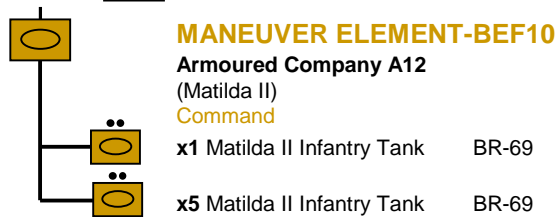
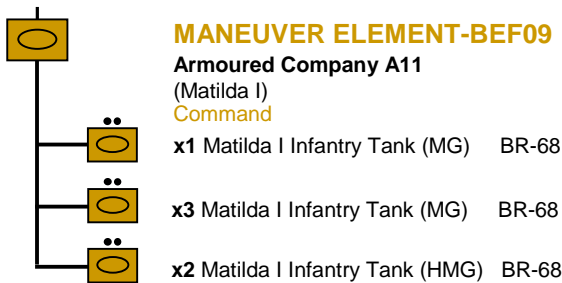
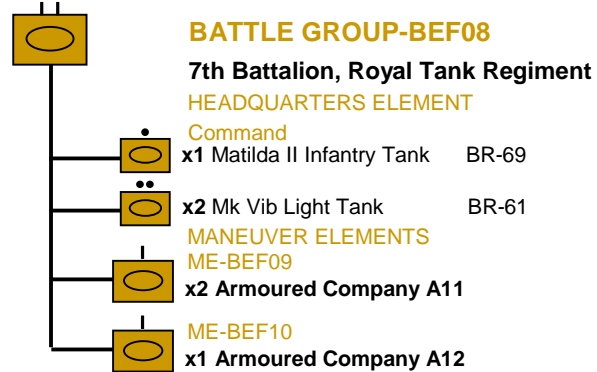
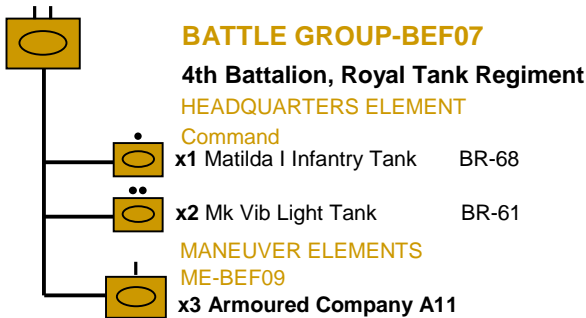

At Arras, the 7RTR lent 4RTR 7xMatilda II to create a mixed company and reorganized their A12 company. This would give both Battalions one mixed company. This would replace one of the A11 companies in 4RTR and the A12 company in 7RTR (note that the command tank in 7RTR might still be a Matilda II):



Just to complicate things, there was considerable attrition due to mechanical breakdown. At Arras, both battalions were 25-30% understrength, so a scenario designer might consider removing 1-2 of the tanks at random from each company if doing the Arras battle.

After Arras the remnants of the two battalions were withdrawn to Carvin and formed into 4/7 RTR with 18 Mk I's, 2 Mk II's and 7 light tanks, the Battlefront representation of which might be:



# 1st Armoured Division/Armoured Formations

The 1st was shipped to France as a separate entity to the BEF.

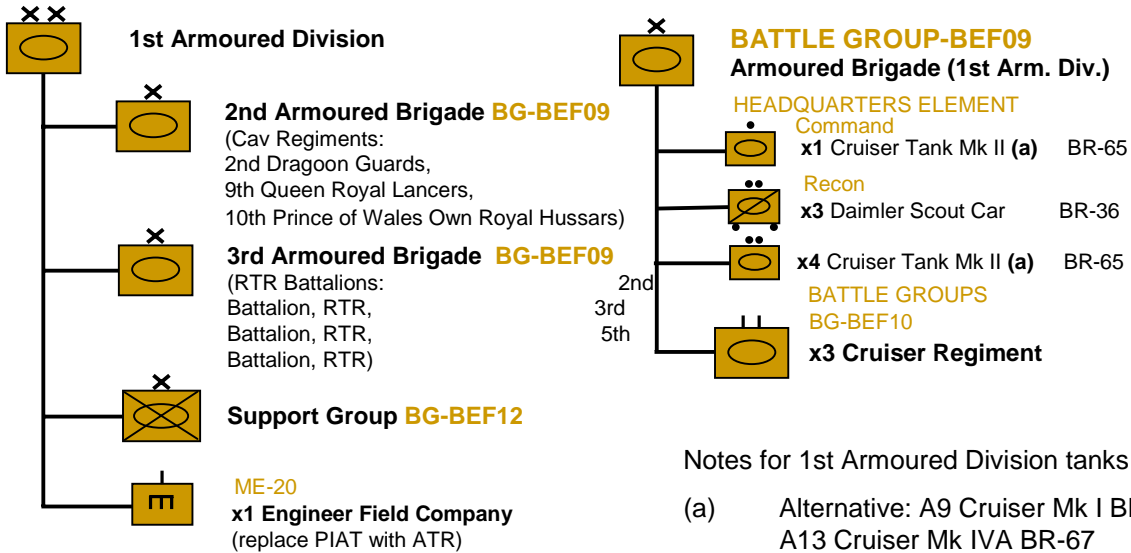

The theoretical organization of the Cruiser Regiments was:

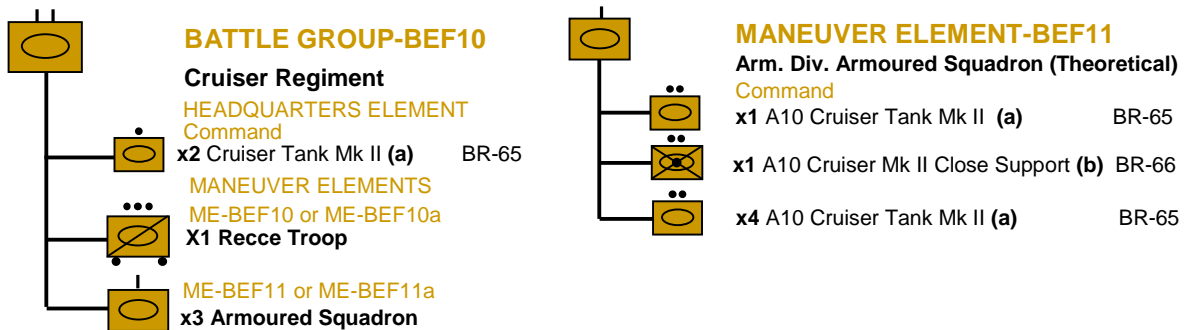

However, the required number of cruisers was not available in 1940 and the two brigades made up the numbers with Mk VI light tanks. This gives a more realistic organization of:

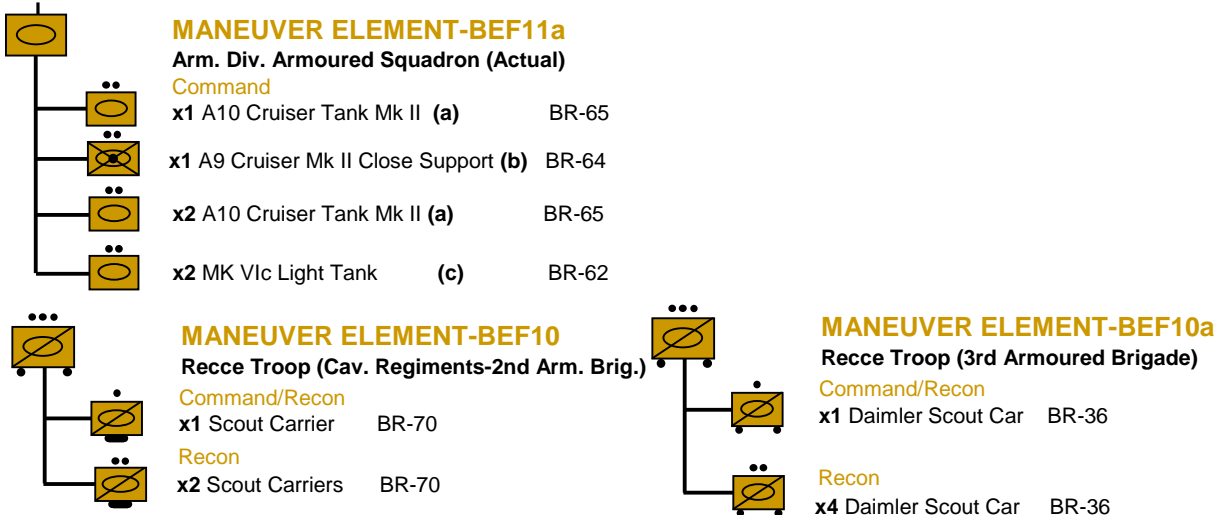

(a) May dismount as Bren LMG BR-53 OR Boys ATR BR-76

# 1st Armoured Division/Support Formations

Although the support group is listed as a separate brigade-level organization, its even number of all major assets makes it likely that its components were used as equal attachments to the armoured brigades.

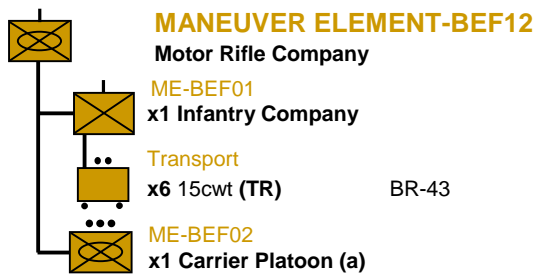
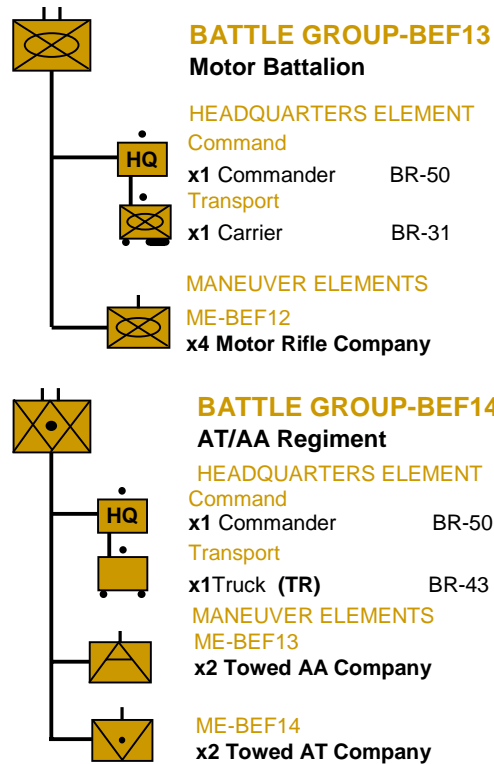
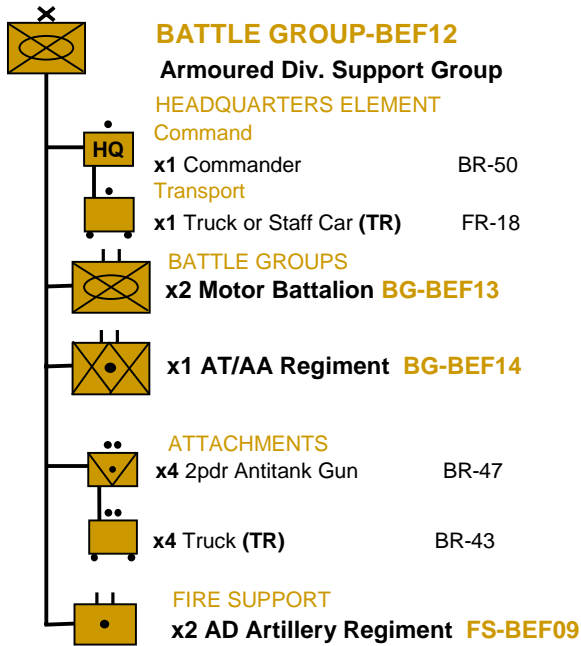

(a) No 2" mortar

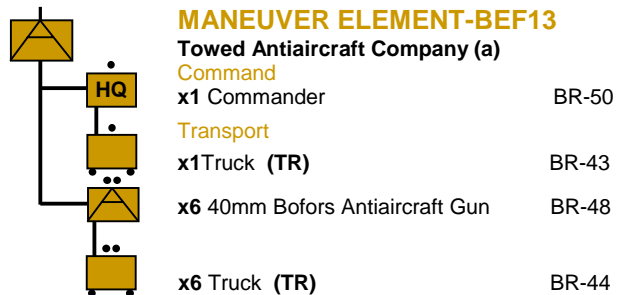

(a) The guns in the towed antiaircraft company may also operate as separate unit attachments to a maneuver element or headquarters element.

Note-This unit was understrength when first shipped to France, and originally had NO Bofors. However, by the time of the campaign it had some. Scenario designers may replace several of the Bofors by AAMG (BR-P13)

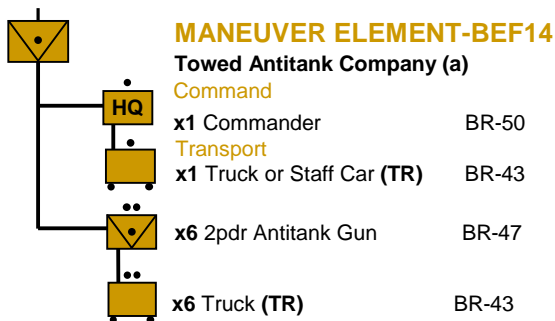

(a) The towed antitank troop may also operate as separate unit attachments to a maneuver element or headquarters element.

# 12th Lancers

The 12th Lancers were a unique BEF cavalry regiment that used the Morris CS9 AC

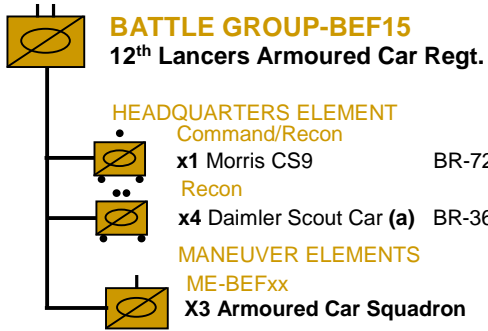

(a) Could be Staff Car (FR-18) as SC were in short supply

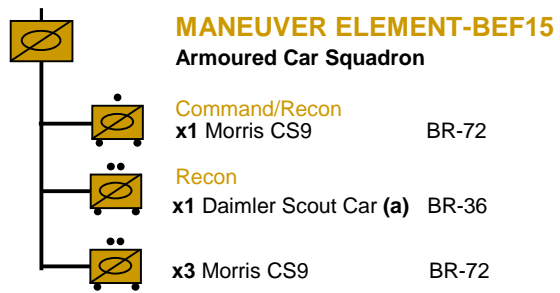

(a) Could be Staff Car (FR-18) as SC were in short supply

# BEF Artillery

## FIRE SUPPORT ELEMENT-BEF-FS01 Field Artillery Regiment

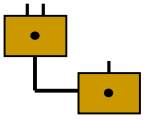

x2 Field Artillery Battery **BEF-FS02**

## FIRE SUPPORT ELEMENT-BEF-FS02 Field Artillery Battery

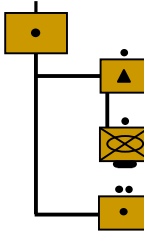

On-board FO Attachment  
x1 Forward Observer BR-52  
Transport  
x1 Universal Carrier No MG(a) BR-31  
Off-board Direct Fire Support  
x6 18/25pdr Towed Field Gun (b)

## FIRE SUPPORT ELEMENT-BEF-FS03 Medium Artillery Regiment

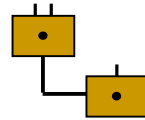

x2 Medium Artillery Battery **BEF-FS02**

## FIRE SUPPORT ELEMENT-BEF-FS04 Medium Artillery Battery

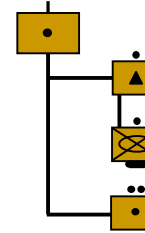

On-board FO Attachment  
x1 Forward Observer BR-52  
Transport  
x1 Universal Carrier No MG(a) BR-31  
Off-board General Fire Support  
x4 4.5" Towed Howitzer (c)

## FIRE SUPPORT ELEMENT-BEF-FS05 Royal Horse Artillery Regiment

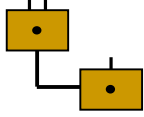

x2 RHA Artillery Battery **BEF-FS06**

## FIRE SUPPORT ELEMENT-BEF-FS06 RHA Artillery Battery

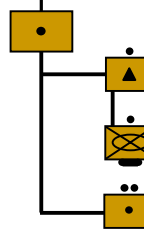

On-board FO Attachment  
x1 Forward Observer BR-52  
Transport  
x1 Universal Carrier No MG(a) BR-31  
Off-board Direct Fire Support  
x4 18/25pdr Towed Field Gun (b)

## FIRE SUPPORT ELEMENT-BEF-FS07 Territorial Field Artillery Regiment

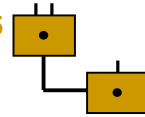

x2 Mixed Field Artillery Battery **BEF-FS08**

## FIRE SUPPORT ELEMENT-BEF-FS08 Mixed Field Artillery Battery

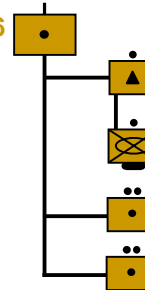

On-board FO Attachment  
x1 Forward Observer BR-52  
Transport  
x1 Universal Carrier No MG(a) BR-31  
Off-board Direct Fire Support  
x4 18pdr Towed Field Gun (d)  
Off-board Direct Fire Support  
x2 4.5" Towed Howitzer (b)

(a) Or soft transport (see note TR)

(b) 18/25-pdr: Large template, -1 vs V, 0 vs T,G,sV

(c) 4.5": Large template, 0 vs V, +1 vs T, G, sV

(d) 18-pdr: Small template, -1 vs V, 0 vs T,G,sV

## FIRE SUPPORT ELEMENT-BEF-FS09 Armoured Division Artillery Regiment

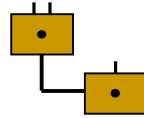

x2 AD Artillery Battery **BEF-FS06**

## FIRE SUPPORT ELEMENT-BEF-FS06 AD Artillery Battery

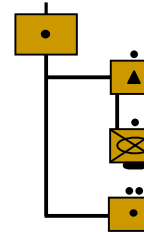

On-board FO Attachment  
x1 Forward Observer BR-52  
Transport  
x1 Universal Carrier No MG(a) BR-31  
Off-board Direct Fire Support  
x4 18 Towed Field Gun (d)