



21. Panzer-Division In Normandy, June 1944

Generalmajor Edgar von Feuchtinger Commanding



'Paper' Organisation



D-Day Reorganisation

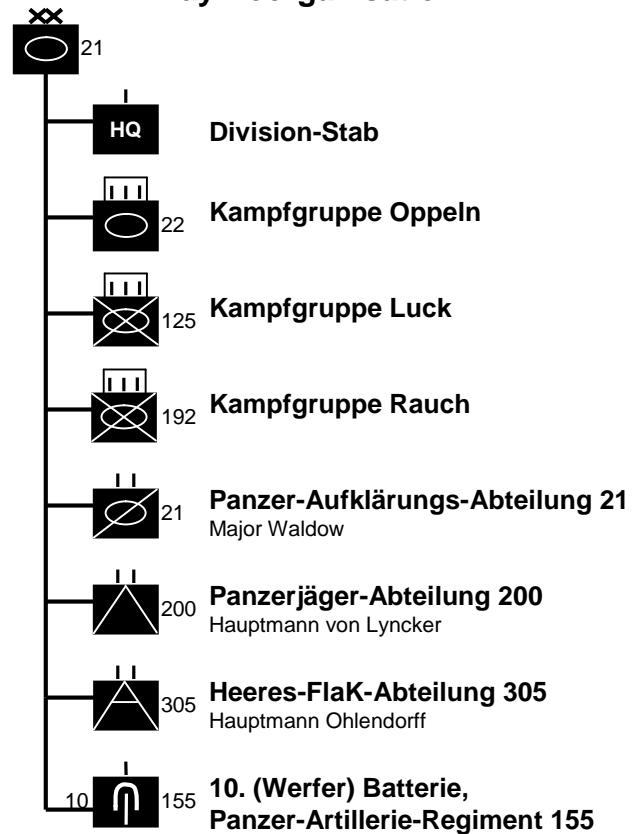

21. Panzer-Division adopted combined-arms battlegroups immediately following the Allied invasion of 6th June. The three battlegroups were formed using the Panzer and Panzer-Grenadier regiments as the nuclei. Panzer-Artillerie-Regiment 155 was split equally, with a battalion of artillery being attached to each group. Panzer-Pionier-Bataillon 220 was split between KGr Oppeln and KGr Rauch (though a company was allocated to KGr Luck after D-Day), while StuG-Abteilung 200 was allocated in its entirety to KGr Luck. Luck and Oppeln meanwhile swapped infantry for panzers, to give each other a limited combined-arms capability.

The divisional reconnaissance, flak and antitank elements, as well as the 10. (Werfer) Batterie of Panzer-Artillerie-Regiment 155, remained under the personal command of the divisional commander as a divisional reserve, though Panzer-Aufklärungs-Abteilung 21 was allocated to KGr Luck for some weeks following D-Day.

So, following this re-organisation, the three regimental battlegroups had very distinct flavours and roles – Oppeln retained the bulk of his panzer regiment and was thus the main armoured fist of the division. However, he had gained some armoured and motorised infantry from Luck. Rauch meanwhile, remained an entirely infantry formation (albeit with some armoured support elements and personnel carriers), and was thus intended to operate in close support of Oppeln. Luck on the other hand, had a well-balanced force of infantry, panzers and assault guns and was therefore quite capable of reasonably independent action. Whether by accident or design, their dispositions on 6th June reflected these divisions in role – Rauch performed a classic infantry/antitank holding action north of Caen while Oppeln prepared to support him and launch his own armoured counter-attack against the bridgehead. Luck meanwhile, operated east of the Orne against British and Canadian paratroopers, divorced from the rest of the division by the nature of the terrain.

The aspect that tends to interest wargamers most about 21. Panzer-Division is the inclusion of large quantities of ex-French vehicles – many of which had been armoured and converted by German engineers – most notably Major Becker. There is still debate as to whether or not the ex-French tanks were involved in the Battle of Normandy, but this argument has still not been resolved. I have included a brief article on German conversions of French vehicles at the end of this order of battle.

Kampfgruppe Rauch (Panzergrenadier-Regiment 192)

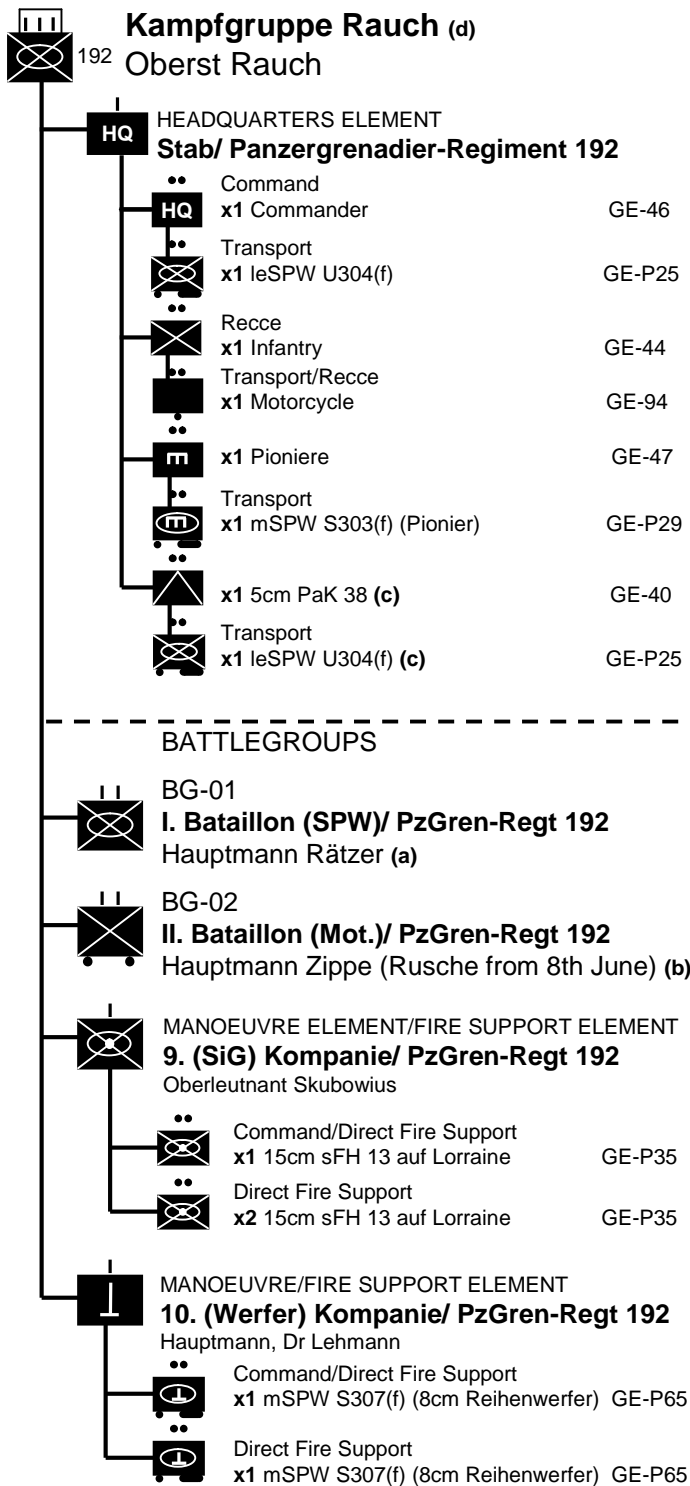

Kampfgruppe Rauch was heavily engaged west of the Orne on D-Day – mainly on the northern approaches to Caen, around Lebissey and Bénouville and in support of Oppeln's panzers and of 716. Infanterie-Division.

(a) Company Commanders in I./192 were as follows:

1. Kompanie – Oberleutnant Braun
2. Kompanie – Hauptmann Gilbert
3. Kompanie – Hauptmann Dönitz
4. Kompanie – Hauptmann Rusche (until 8th June)

(b) Company Commanders in II./192 were as follows:

5. Kompanie – Hauptmann Kerber
6. Kompanie – Oberleutnant Kuhbier
7. Kompanie – Oberleutnant Walter
8. Kompanie – Oberleutnant Braatz

(c) The platoon of PaK 38s does not appear in this regiment in some sources.

(d) Oberst Rauch was formed from Panzer-Grenadier-Regiment 192 on D-Day. The Kampfgruppe was stationed in the northern suburbs of Caen and was tasked with forming a stop-line to prevent the Allies driving into the city from the sea. Elements of the Kampfgruppe (mainly Oberleutnant Braatz's 8. Kompanie) also mounted counter-attacks against the British Airborne position at Bénouville and Pegasus Bridge.

DIVISIONAL ATTACHMENTS

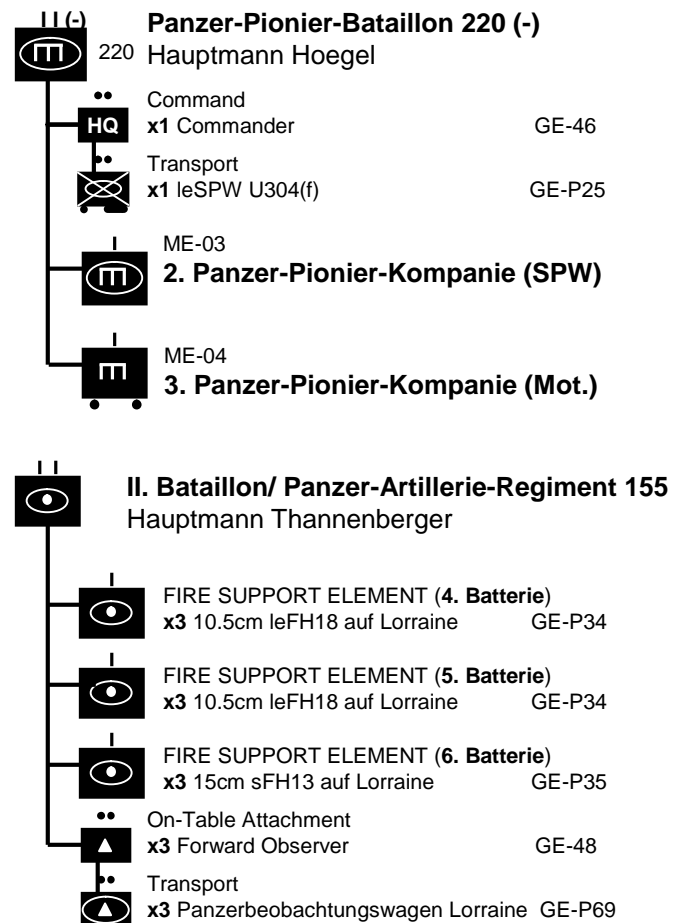

Kampfgruppe Oppeln (Panzer-Regiment 22)

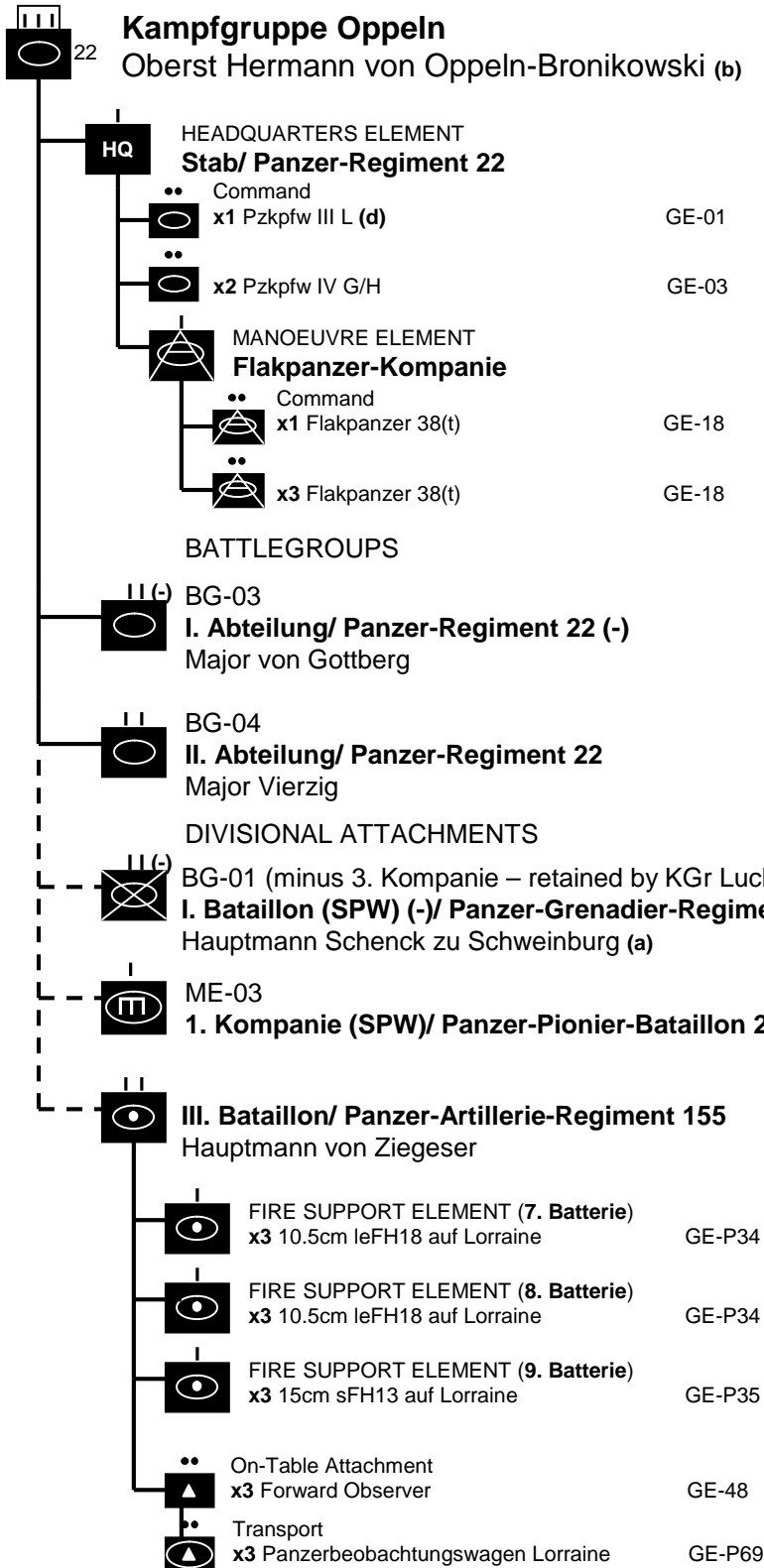

(a) Company Commanders in I./125 were as follows:

1. Kompanie - ?
2. Kompanie - ?
3. Kompanie – Leutnant Bandomir
4. Kompanie – Oberleutnant Wendorff

(b) Panzer Regiment 22 had been numbered as Panzer Regiment 100 until shortly before D-Day and is often referred to by its old number in many sources. Kampfgruppe Oppeln was created from the regiment on D-Day. The Kampfgruppe was stationed at Falaise, some distance to the south of Caen on D-Day and was only able to put in a counter-attack against the Allied bridgehead late in the afternoon. While the majority of the Kampfgruppe became embroiled in a bitter battle north of Caen, one small detachment succeeded in reaching the coast between the 'Sword' and 'Juno' landing beaches. However, this small group was forced to retire in the evening due the landing of the British 6th Airlanding Brigade in its rear.

(c) 1./Panzer-Pionier-Bataillon 220 was transferred to KGr Luck on 7th June.

(d) The command Pzkw III may have been an unarmed Befehlswagen variant, in which case use:
Panzerbeobachtungswagen III GE-20

Kampfgruppe Luck (Panzergrenadier-Regiment 125)

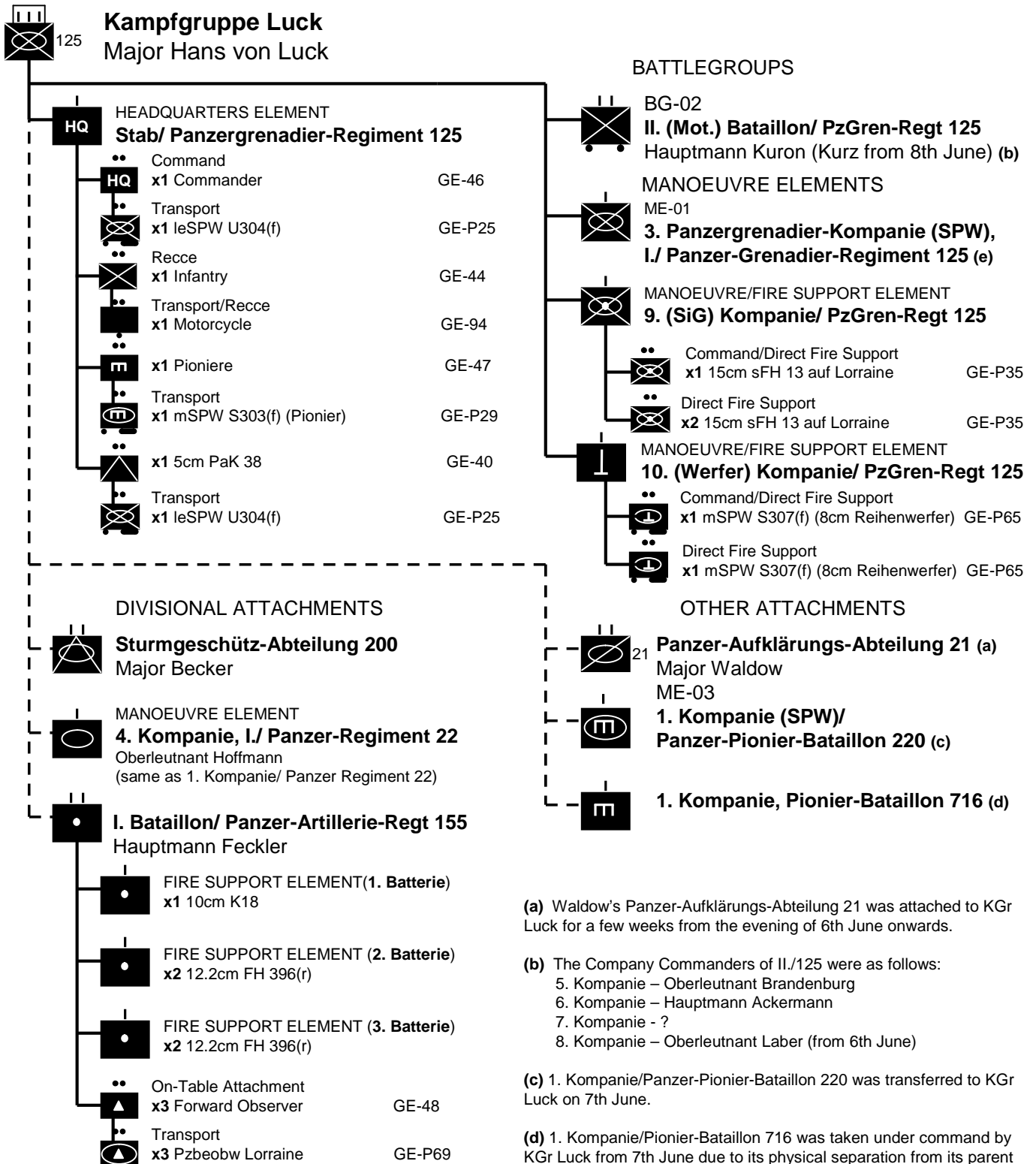

(a) Waldow's Panzer-Aufklärungs-Abteilung 21 was attached to KGr Luck for a few weeks from the evening of 6th June onwards.

(b) The Company Commanders of II./125 were as follows:
 5. Kompanie – Oberleutnant Brandenburg
 6. Kompanie – Hauptmann Ackermann
 7. Kompanie – ?
 8. Kompanie – Oberleutnant Laber (from 6th June)

(c) 1. Kompanie/Panzer-Pionier-Bataillon 220 was transferred to KGr Luck on 7th June.

(d) 1. Kompanie/Pionier-Bataillon 716 was taken under command by KGr Luck from 7th June due to its physical separation from its parent 716. Infanterie-Division. It is also mentioned that the Pionier-Zug of StuG-Abteilung 200 took some stragglers from 711. Infanterie-Division under their wing on 7th June.

(e) Some sources list 1. Kompanie/ Panzer-Grenadier-Regiment 125 as being with KGr Luck, though Lt Bandomir's writings and photographs are quite clear on the matter – it was his own 3. Kompanie that provided the SPW element in KGr Luck.

Note on Kampfgruppe Luck:

The Kampfgruppe was stationed east of the Orne on D-Day, with one company actually conducting an anti-parachute exercise when the landings started. This availed them none, however, as this company was only armed with blank ammunition! Von Luck quickly mobilised his Kampfgruppe and soon counterattacked against the British-Canadian 6th Airborne Division near Ranville – being the first major German formation to do so. Contrary to his claims however, he was not involved in the battle for Pegasus Bridge, though elements of his Panzergrenadier-Regiment 125 were involved, but actually as part of Kampfgruppe Oppeln. Von Luck spent the entire campaign east of the Orne and was instrumental in halting the Operation ‘Goodwood’ offensive in July at Bourguébus Ridge.

Battalion Battlegroups (Panzergrenadiers)

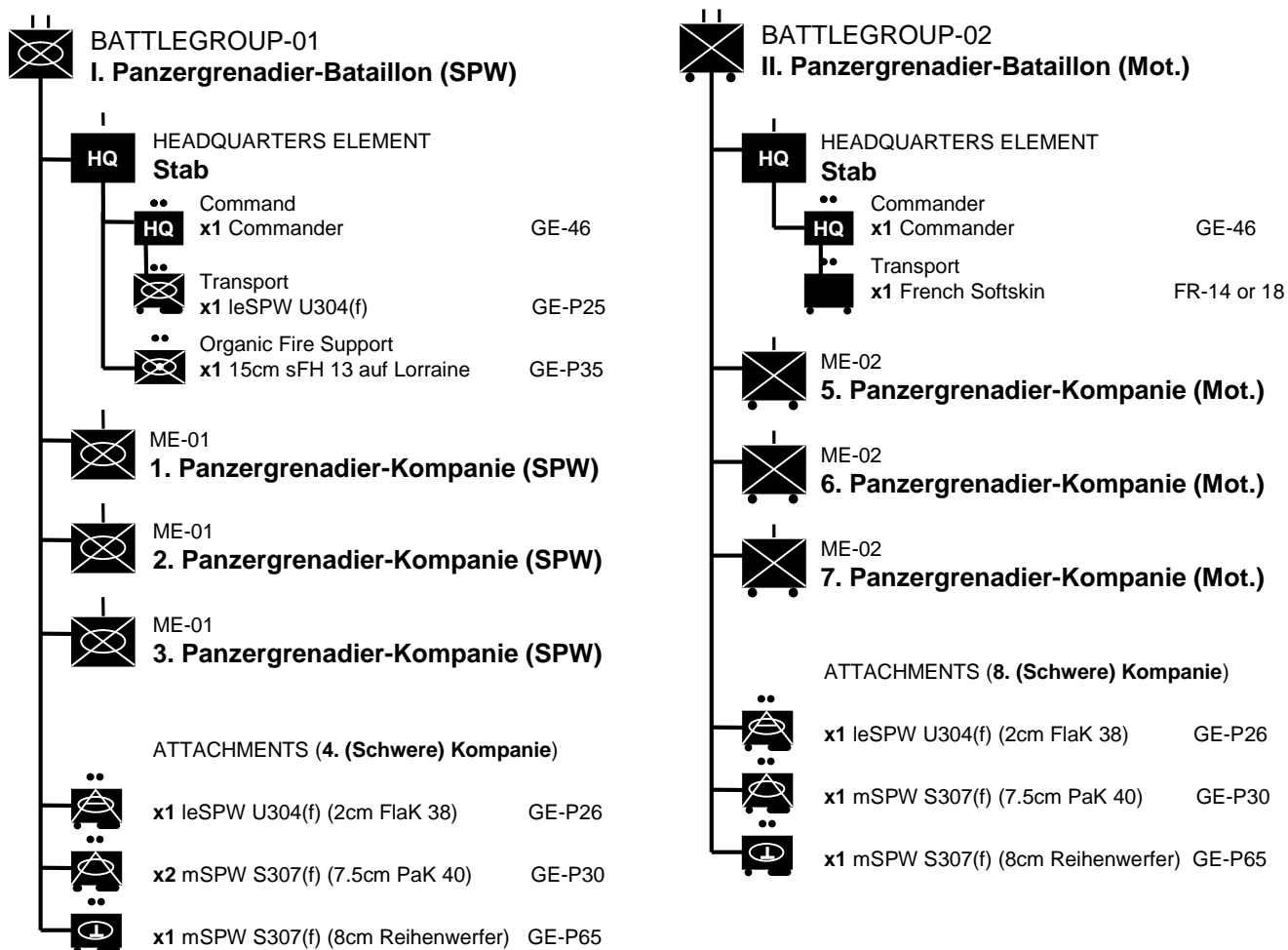

Note:

The battalion organisation was identical in both the 125. And 192. Panzergrenadier Regiments, as listed above.

Battalion Battlegroups (Panzers)

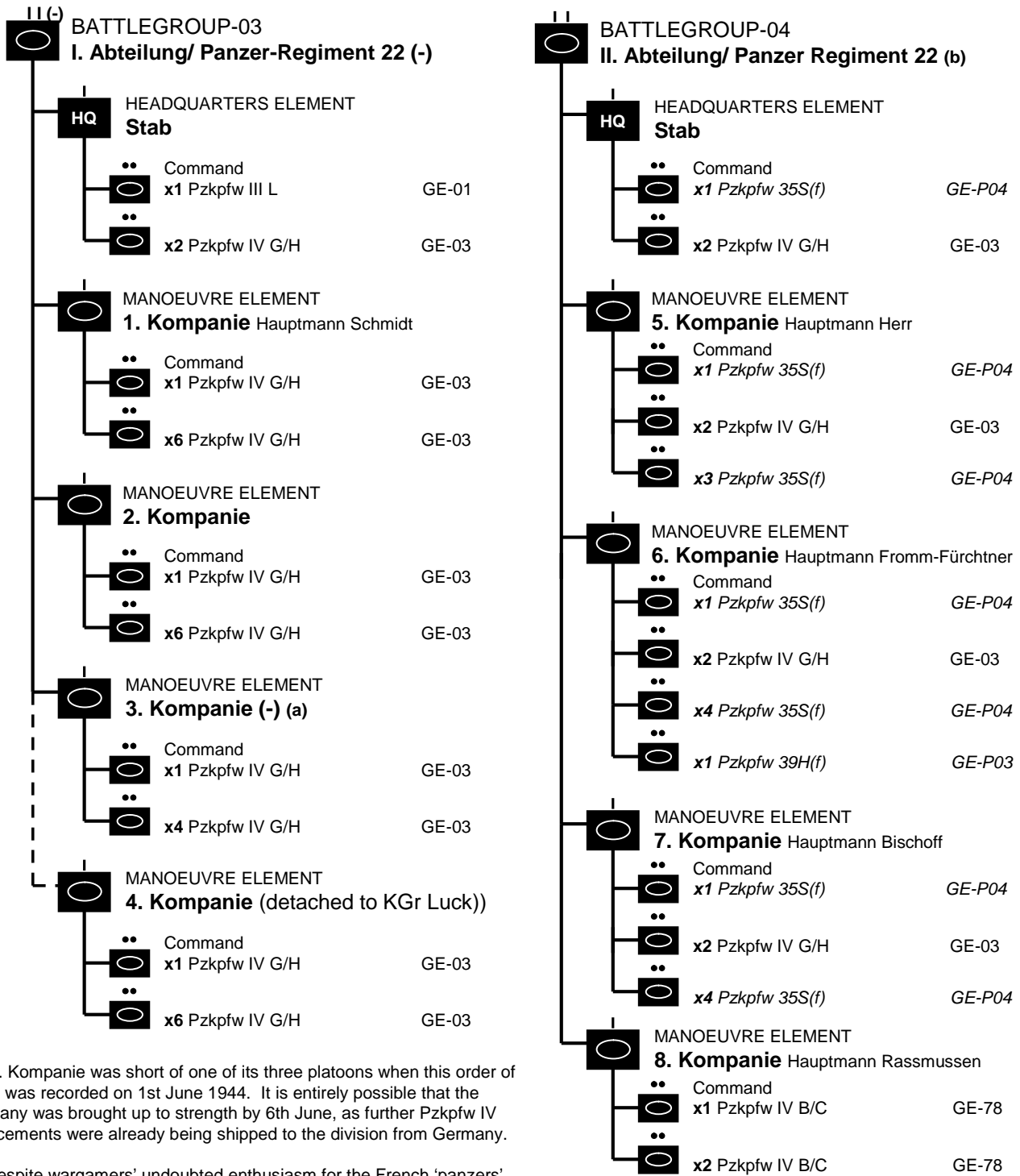

(a) 3. Kompanie was short of one of its three platoons when this order of battle was recorded on 1st June 1944. It is entirely possible that the company was brought up to strength by 6th June, as further Pzkw IV replacements were already being shipped to the division from Germany.

(b) Despite wargamers' undoubted enthusiasm for the French 'panzers' (including my own), evidence for their combat use within Panzer-Regiment 22 is non-existent. These strengths are based on the returns of 1st June, though it would seem that the crews departed soon afterwards for the panzer training ground at Mailly-le-Camp to collect and train with new Pzkw IVs that had already been dispatched from Germany (these new panzers reached the division in early July). Oppeln's orders for his attack on the afternoon of 6th June only lists numbers of Pzkw IVs at his disposal – it makes no mention whatsoever of the Somuas and Hotchkisses listed above. Therefore, for historical scenarios remove the French panzers and treat each company (except 8. Kompanie) in II. Bataillon as an independent platoon of x2 Pzkw IV G/H. Designate one Pzkw IV in each company as the command tank. 8. Kompanie kept its obsolete short-gunned Pzkw IVs throughout the Normandy Campaign (though it may have been reinforced).

Sturmgeschütz-Abteilung 200

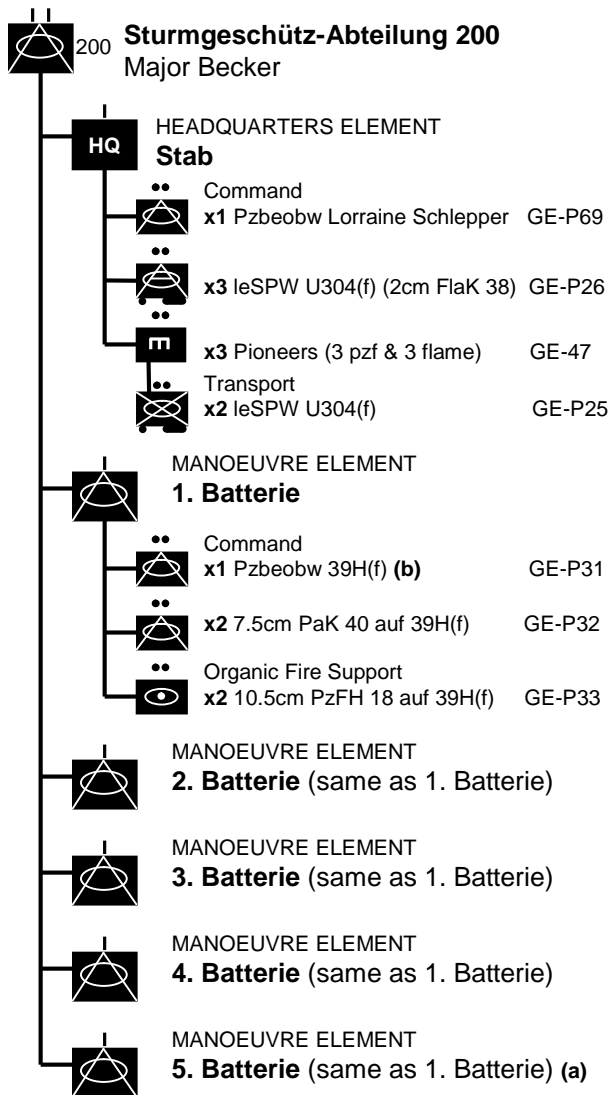

(a) 5. Kompanie/StuG-Abt 200 was still being trained on 6th June, though was used as the battalion reserve in the Caen area and eventually saw action during July. There was also a 6. Kompanie being raised, though this did not see action as a unified unit and was broken up to provide replacements for the heavy casualties suffered by the abteilung during the defence against Operation 'Goodwood'.

(b) The Battery command vehicles may function as Forward Observers for the 10.5cm howitzer vehicles in the battery.

Panzer-Aufklärungs-Abteilung 21

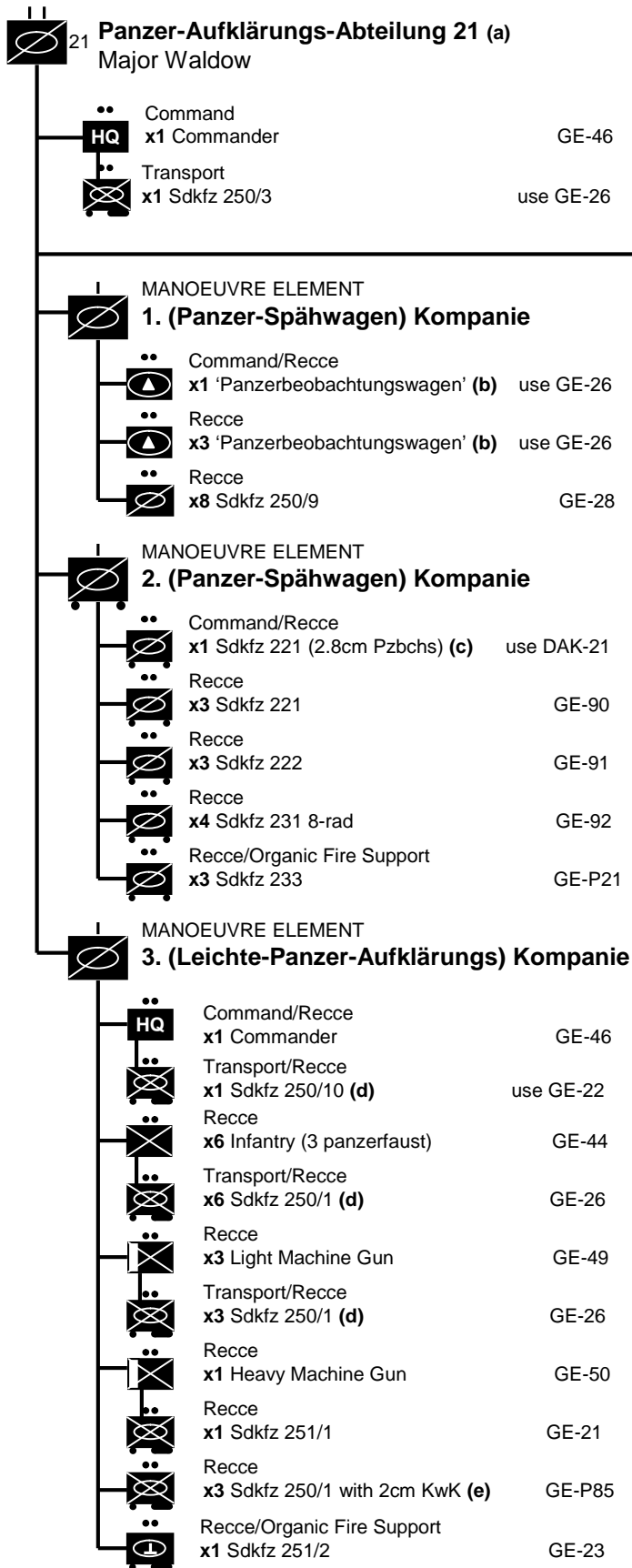

MANOEUVRE ELEMENT

4. (Leichte-Panzer-Aufklärungs) Kompanie

Organised the same as 3. Kompanie, though delete the x3 Sdkfz 250/1 2cm cannon variants and add an additional x1 MG42 HMG plus x1 Sdkfz 250/1.

ATTACHMENTS

5. (Schwere-Panzer-Aufklärungs) Kompanie

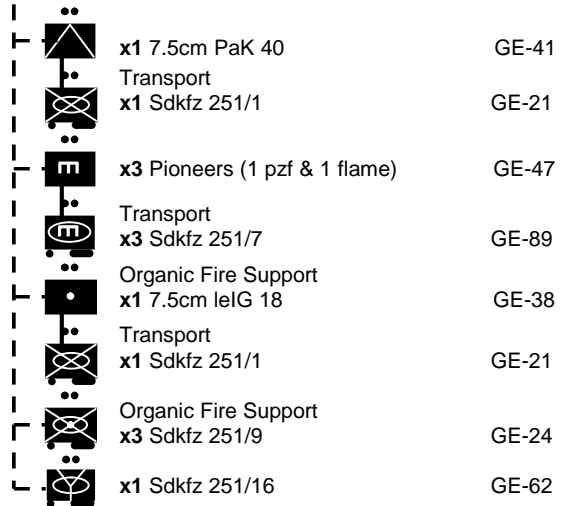

(a) The battalion was stationed a long way to the south – approximately 10km South-East of Condé-sur-Noireau – and was not therefore engaged on D-Day. It came under command of KGr Luck late that evening and was in action on 7th June.

(b) Probably OP/command versions of the Sdkfz 250 such as the 250/4, 250/5 or 253 (use GE-26). It's also possible that they might have been Panzerbeobachtungswagen Lorraine (f), which were used by the divisional artillery (though this is pure speculation).

(c) This version of the Sdkfz 221, mounting the 2.8cm Pzbchs, was rare, though was found in other units in Normandy. It can be found in the Desert War Supplement.

(d) Some of these might also be leSPW U304(f) as for the Panzergrenadier Regiments.

(e) While these vehicles are described in Perrigault's book as 'leSPW U304(f) (2cm FlaK 36)', the photographs make it clear that they are not. While the (two) photos only show upper parts of the vehicles, the vehicles are clearly Sdkfz 250 and the guns are pintle-mounted 2cm cannon, mounted in lieu of the usual MG or 3.7cm PaK 36.

Manoeuvre Elements Not Previously Detailed

MANOEUVRE ELEMENT-01 Panzergrenadier-Kompanie (SPW)

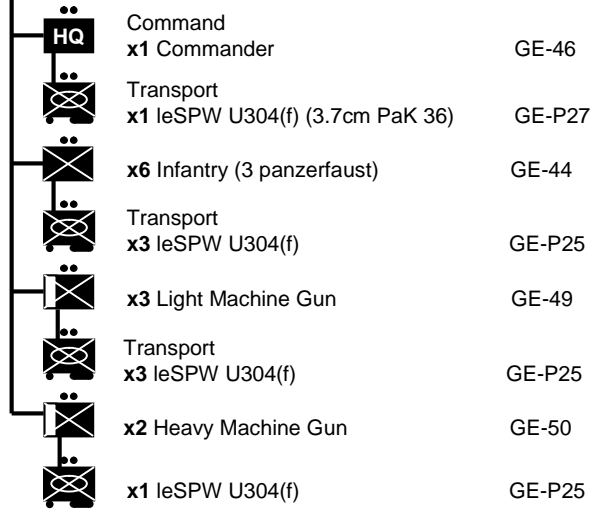

MANOEUVRE ELEMENT-03 Panzer-Pionier-Kompanie (SPW)

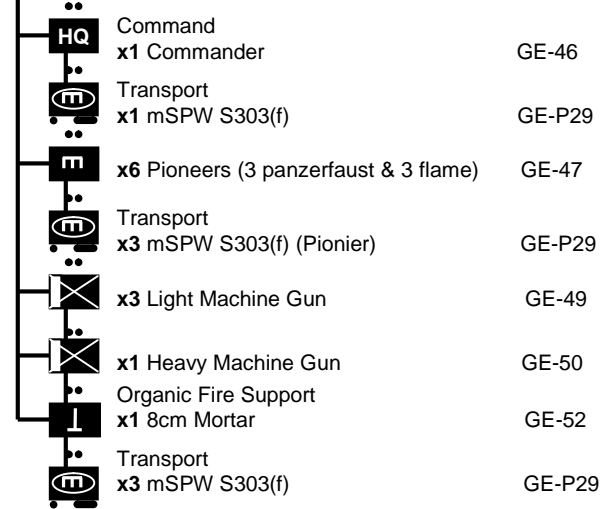

MANOEUVRE ELEMENT-02 Panzergrenadier-Kompanie (Mot.)

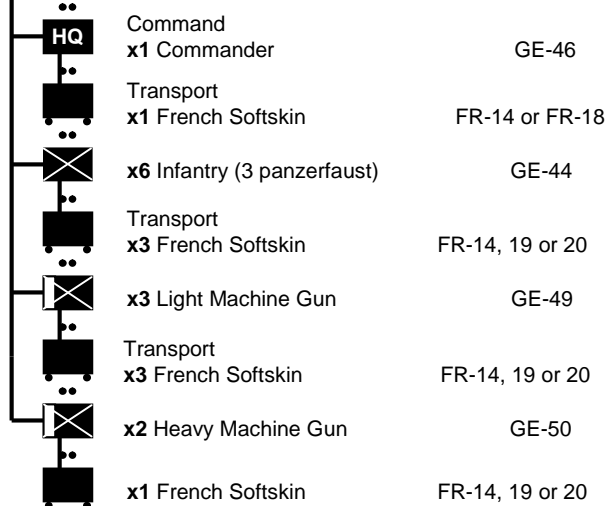

MANOEUVRE ELEMENT-04 Panzer-Pionier-Kompanie (Mot.)



Other Divisional Elements

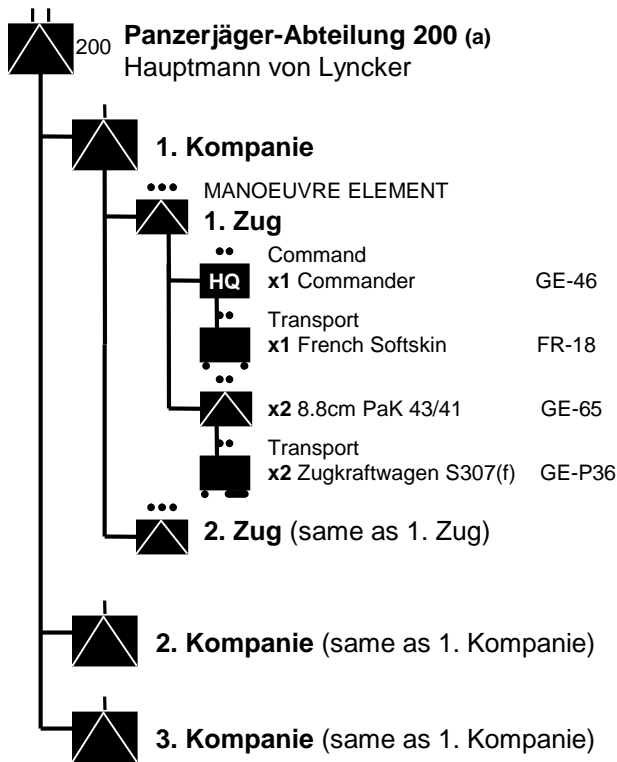

(a) 21. Panzer Division was the only panzer division in Normandy to field the PaK 43/41. These three companies were stationed as follows on D-Day:

1. Kompanie: Between Caen and Bayeux.
2. Kompanie: At Putot-en-Bessin and Le Fresne-Camilly.
3. Kompanie: At Basly (15km NW of Caen)

The battalion was heavily involved in halting the Allied drive to Caen on D-Day.

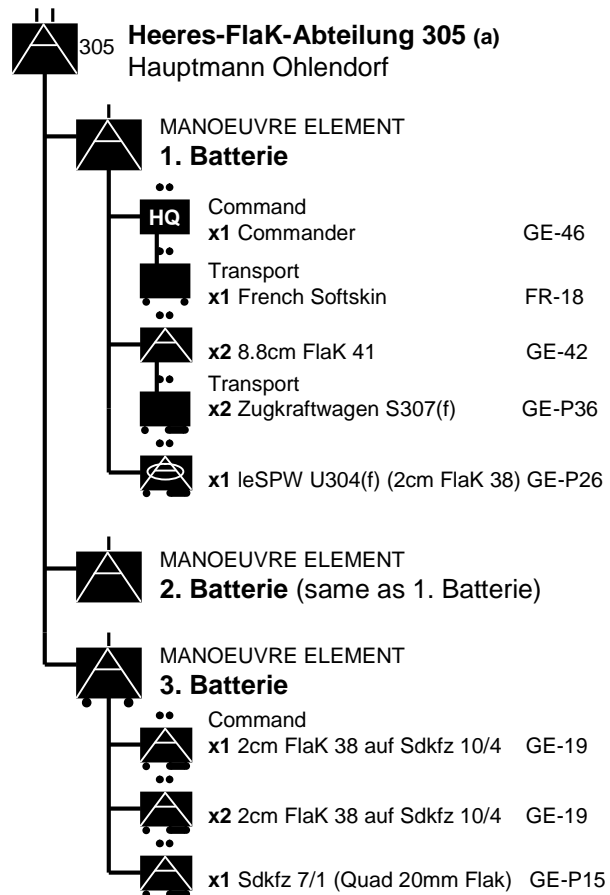

(a) The battalion was deployed as follows on D-Day:

1. Batterie: On the South-East edge of Caen.
2. Batterie: To the West of Caen.
3. Batterie: On the Eastern edge of Caen.

It was at least partly re-deployed to the northern suburbs of Caen and Lebissey, where it was involved in halting the Allied advance on the city on 6th June.

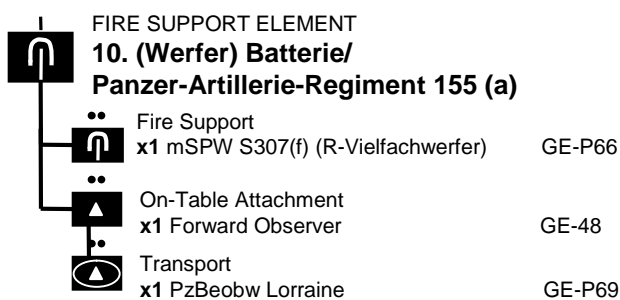

(a) Not attached to any particular battalion in the regiment. It was stationed around Bourguébus on D-Day and so would be in a position to immediately support Kampfgruppe Luck.

Deployment Of 21. Panzer-Division 5th June 1944

21. Panzer-Division Stab

- Saint-Pierre-sur-Dives

Panzer-Grenadier-Regiment 125 Stab

I. Bataillon Stab/125

1-4. Kompanien/125

II. Bataillon Stab/125

5-8. Kompanien/125

9. Kompanie/125

10. Kompanie/125

- Vimont (13km SE of Caen)

- Fierville la Campagne (18km SE of Caen)

- Saint-Sylvain, Fierville la Campagne, Vieux-Fumé & Vimont

- Colombelles (5km NE of Caen)

- Troarn, Banneville la Campagne, Escoville(?) & Colombelles

- Colombelles

- Colombelles

Panzer-Grenadier-Regiment 192 Stab

I. Bataillon Stab/192

1-4. Kompanien/192

II. Bataillon Stab/192

5-8. Kompanien/192

9. Kompanie/192

10. Kompanie/192

- Thury-Harcourt (27km SE of Caen)

- Verson (7km SW of Caen)

- Verson, Fontaine-Etoupefour & Carpiquet

- Mesnil

- Château de la Londe, Buron, Périers-sur-le-Dan & Cairon

- Croisilles

- Thury-Harcourt

Panzer-Regiment 22 Stab

I. Bataillon Stab/22

1-4. Kompanien/22

II. Bataillon Stab/22

5-8. Kompanien/22

- Aubigny (3km N of Falaise)

- Jort (8km SE of Saint-Pierre-sur-Dives)

- Jort & 4. Kp in Epaney

- Fresné-la-Mère (5km E of Falaise)

- Fresné-la-Mère

Panzer-Aufklärungs-Abteilung 21

- Segrie-Fontaine (10km SE of Condé-sur-Noireau)

Panzer-Artillerie-Regiment 155 Stab

I. Bataillon Stab/155

1-3. Batterien/155

II. Bataillon Stab/155

4-6. Batterien/155

III. Bataillon Stab/155

7-10. Batterien/155

- ?

- Mathieu

- Beauville, Périers-sur-le-Dan & Colomby-sur-Thaon

- ?

- Saint-André-sur-Orne, Saint-Martin-de-Fontenay & May-sur-Orne

- ?

- Saint-Aignan-de-Cramesnil & Bourguébus

StuG-Abteilung 200

- Cagny, except 5. Batterie at Epron (possibly without vehicles yet)

Panzerjäger-Abteilung 200

- Batteries deployed Martragny-St-Croix, Putot-en-Bessin & Basly

Heeres-FlaK-Abteilung 305

- Batteries deployed SE, W & E of Caen

Panzer-Pionier-Bataillon 220 Stab

1. Kompanie/220

2. Kompanie/220

3. Kompanie/220

- Saint-Rémy

- Quesnay

- Detached to Gaillon & Vernon

- Creully

Rommel's Funnies

The following is a list of some the various improvised designs, based on captured French vehicles, that were used by various units in Normandy:

Zugkraftwagen P107/304(f)	- Softskin half-track, based on the Unic P107 halftrack.
leSPW U304(f)	- APC variant of the P107 - similar to the Sdkfz 251 series. QRF & FoW do a model.
leSPW U304(f) (Funk)	- Equivalent of the Sdkfz 251/3 or 251/8 radio/command vehicles.
leSPW U304(f) (2cm FlaK 36)	- Equivalent of the Sdkfz 251/17, mounting the 20mm FlaK 36. QRF & FoW do a model.
leSPW U304(f) (3.7cm PaK 36)	- Equivalent of the Sdkfz 251/10, mounting the 37mm PaK 36. FoW do a model.
Zugkraftwagen S303(f)	- Softskin half-track, based on the Somua MCL halftrack.
Zugkraftwagen S307(f)	- Softskin half-track, based on the Somua MCG halftrack.
mSPW S303(f)	- APC halftrack based on the Somua MCL. Equivalent of the Sdkfz 251/.
mSPW S307(f)	- APC halftrack based on the Somua MCG. Equivalent of the Sdkfz 251/1. FoW do a model.
mSPW S307(f) (7.5cm PaK 40)	- Equivalent of the Sdkfz 251/22 - an armoured version of the Somua half-track, mounting the 75mm PaK 40. QRF & FoW do a model.
mSPW S303/307(f) (8cm Reihenwerfer)	- Mounting an incredible sixteen, twenty or twenty-two French 81mm mortars on a single mount! Use 8cm mortar stats but use a large template. QRF & FoW do a model.
mSPW S303(f) (Pionier)	- Equivalent of the Sdkfz 251/7. FoW do a model.
mSPW 303/307(f) (R-Vielfachwerfer)	- Mounting two racks of 8cm 'Stalin's Organ' Katyusha Rockets (or German copies thereof). QRF & FoW do a model.
Pzkwf 35S(f)	- Ex-French Somua S35 tank with few differences to the original design (47mm gun). Skytrex/Old Glory produce a beautiful model of this tank – one of their best ever. QRF & FoW also do models. Add a split hatch on the cupola for the German version.
Pzkwf 35/38/39H(f)	- Ex-French Hotchkiss H35/38/39 tanks with few differences to the original designs (short or long 37mm gun). Peter Pig, FoW & QRF produce models. Add a split hatch to the cupola for the German version.
Panzerbeobachtungswagen 39H(f)	- Open-topped forward observation vehicle based on the Pzkwf 39H(f).
Pzkwf B2(f)	- Ex-French Renault Char B1bis, with little or no differences to the original design (47mm turret gun and 75mm hull gun). Again, Skytrex produce a beautiful model. QRF and FoW also produce models. Add a split hatch on the cupola for the German version.
Pzkwf B2(f) Flamm	- Pzkwf B2(f) retaining the turret-mounted 47mm, but with the hull-mounted 75mm replaced by a flamethrower. Later models had an altered front with two vision slits and a large fuel tank on the rear. FoW include the parts in their Pzkwf B2(f) to model the Flammpanzer variant.
Pzbeobw auf Lorraine Schlepper (f)	- Artillery observation vehicle based on French Lorraine armoured carrier, with a totally redesigned superstructure. FoW do a lovely little model.
7.5cm PaK 40 auf 39H(f)	- Panzerjäger based on Hotchkiss tank. Battlefront Miniatures used to produce a model of this. QRF and FoW do a model.
10.5cm PzFH 18 auf 39H(f)	- Wespe-equivalent based on Hotchkiss H39 tank. Again, Battlefront produce a model of this. QRF and FoW do a model.
10.5 cm leFH 18 auf Lorraine Schlepper	- Wespe-equivalent based on Lorraine armoured carrier. QRF & FoW do a model.
15cm sFH 13 auf Lorraine Schlepper	- Bison/Grille-equivalent based on Lorraine armoured carrier. FoW & QRF do a model.
7.5cm PaK 40 auf Lorraine (Marder I)	- Panzerjäger based on Lorraine armoured carrier. FoW & QRF do a model.
Panzerjäger 35R(f) (4.7cm PaK(t))	- Panzerjäger I-equivalent, based on the Renault R35 tank. QRF do a model.
Morserträger 35R(f) (8cm GrW)	- 8cm mortar carrier based on the Pzkwf 35R(f) hull. QRF do a model.
UE Schlepper 430(f)	- A tiny, tankette-type gun tractor with tracked, armoured trailer. Used by a lot of German units as a gun-tractor or armoured resupply vehicle. A few independent panzer units used them as 28/32cm Wurffrahmen launch-vehicles. QRF do a model.
Panzerjäger UE 430(f) (3.7cm PaK 36)	- Some UEs were converted to panzerjägers by the addition of a 3.7cm PaK 36 precariously mounted on top. There was no protection for the gunners beyond the PaK 36's gun-shield. QRF do a model.
Softskins	- 21. Panzer-Division had over 50 different softskin types - mainly French, but also some Italian. Common makes of truck included Citroën, Laffly and Renault, while Unic P107 and Somua MCL & MCG softskin halftracks were very common – particularly in the II. (unarmoured) battalions of the 192nd and 125th Panzergrenadier Regiments. These were also used by a great many German units in Normandy.

There was a bewildering array of converted ex-French vehicles in the German army, though many had been retired by 1944, or had gone to client states such as Croatia. I really have only scratched the surface with the list above. Many types were so similar in function and appearance to these, that they aren't really worth listing in exhaustive detail. However, other possible (and significantly different) vehicles include Renault R35 & Hotchkiss H35 light tanks converted into 8cm mortar carriers in place of the mortar halftracks in the panzergrenadier battalions. Some Renault R35s were fitted with 2cm cannon and converted into recce tanks. Many light tank types were also converted into carriers for 15cm *Panzerwerfer* 42 and heavier rockets – fitting the Pzkwf 35/39H(f) with 4x 28/32cm *Wurffrahmen* was a popular conversion.

Select Bibliography

- '21. Panzer-Division' – Jean-Claude Perrigault
- 'The Panzers and the Battle of Normandy' – Georges Bernage
- 'Panzers in Normandy, 1944' – Eric Lefèvre
- 'The German Order of Battle – Vol. 1' – George Nafziger
- 'D-Day Tank Warfare' – Steven J Zaloga & George Balin
- 'La Bataille de Caen' – Georges Benamou
- 'Normandy 1944 – German Military Organisation, Combat Power & Organisational Effectiveness' – Niklas Zetterling
- 'Captured French Tanks Under The German Flag' – Werner Regenber & Horst Scheibert
- 'Panzer Commander' – Hans von Luck
- 'Panzer-Truppen – Vol. 2' – Thomas Jentz