

Greek TO&Es 1980-1989 v1.2

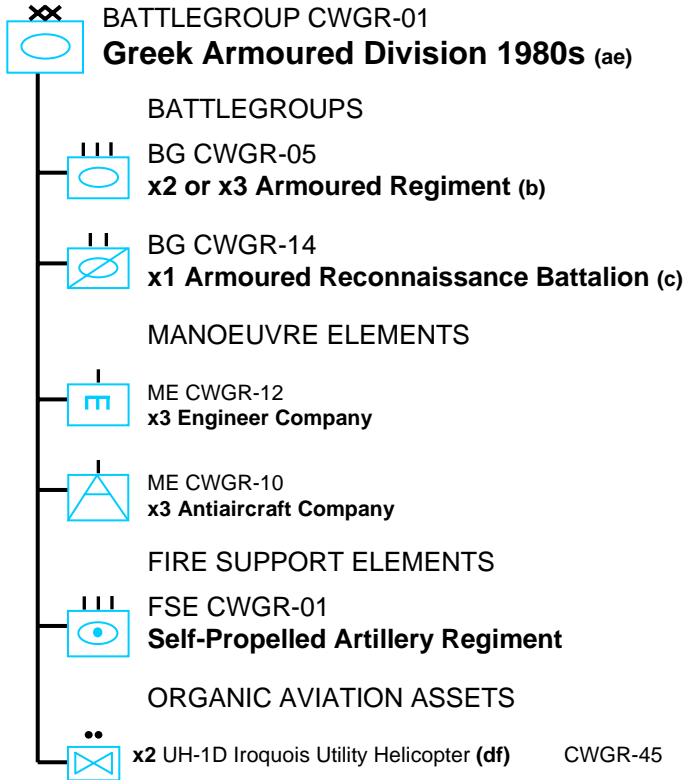

(a) The Greek Army had only **x1** Armoured Division: 20th Armoured Division. There were also **x3** Independent Armoured Brigades, which were organised exactly the same as Armoured Regiments within 20th Armoured Division (BG CWGR-05). Indeed, the brigades were occasionally rotated though 20th Armoured Division, earning the designation 'Regiment' as they did so.

(b) During the early 1980s there were **x3** Armoured Regiments within 20th Armoured Division and **x2** Independent Armoured Brigades. However, this situation was reversed at some point, so that by 1989 there were **x2** Armoured Regiments and **x3** Independent Armoured Brigades. The Armoured Regiments/Brigades were numbered 21st to 25th. 21st & 25th Brigades had M48 tanks, while 22nd & 23rd Brigades had AMX-30 and 24th Brigade had Leopard 1. In terms of APCs, it would appear that AMX-10 P MICVs were paired up with the AMX-30 tanks and Leonidas APCs were paired up with the Leopards. M113s equipped the rest.

(c) Each Greek Corps also had a Reconnaissance Battalion.

(d) May replace UH-1D Iroquois with:
 AB205 Utility Helicopter (Italian-built UH-1D) same card

(e) Each Greek Corps (designated A, B, C & D) had a Reconnaissance Battalion (BG CWR-14), as mentioned above. I can't find any more information, but I would imagine that each Corps would also have additional engineers and possibly air defence artillery. Artillery Brigades were also formed, though they seem to have been formed from the existing heavier divisional artillery units, rather than being entirely new units. There were also two corps-sized 'Commands' that functioned as reserve formations, but which did not contain any corps troops.

(f) The allocation of helicopters in the Greek Army & Air Force is not very clear. In 1982 the Army and Air Force had **x28** UH-1D and **x32** AB-204/205/206 between them (AB-204 is Italian (Agusta-Bell) licence-built UH-1B, AB-205 is licence built UH-1D and AB-206 is licence-built OH-58). They appear to have had a flight of **x2** helicopters in each division (listed above), which would account for **x24** helicopters. I also have a reference to the Greeks ordering a small squadron of **x4** AH-1S Cobra Attack Helicopters (CWGR-46) in 1982, but I don't know if the order was ever completed or if they then ordered more.

 BATTLEGROUP CWGR-02
Greek Mechanised Division 1980s (ad)

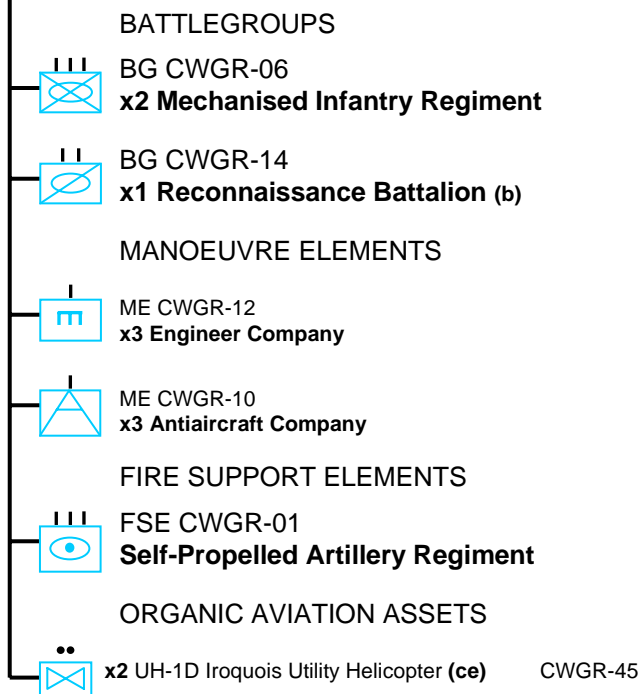

(a) The Greek Army had only **x1** Mechanised Division: 2nd Mechanised Division.

(b) Each Greek Corps also had a Reconnaissance Battalion.

(c) May replace UH-1D Iroquois with:
 AB205 Utility Helicopter (Italian-built UH-1D) same card

(d) Each Greek Corps (designated A, B, C & D) had a Reconnaissance Battalion (BG CWR-14), as mentioned above. I can't find any more information, but I would imagine that each Corps would also have additional engineers and possibly air defence artillery. Artillery Brigades were also formed, though they seem to have been formed from the existing heavier divisional artillery units, rather than being entirely new units. There were also two corps-sized 'Commands' that functioned as reserve formations, but which did not contain any corps troops.

(e) The allocation of helicopters in the Greek Army & Air Force is not very clear. In 1982 the Army and Air Force had **x28** UH-1D and **x32** AB-204/205/206 between them (AB-204 is Italian (Agusta-Bell) licence-built UH-1B, AB-205 is licence built UH-1D and AB-206 is licence-built OH-58). They appear to have had a flight of **x2** helicopters in each division (listed above), which would account for **x24** helicopters. I also have a reference to the Greeks ordering a small squadron of **x4** AH-1S Cobra Attack Helicopters (CWGR-46) in 1982, but I don't know if the order was ever completed or if they then ordered more.

 BATTLEGROUP CWGR-03
Greek Infantry Division 1980s (ad)

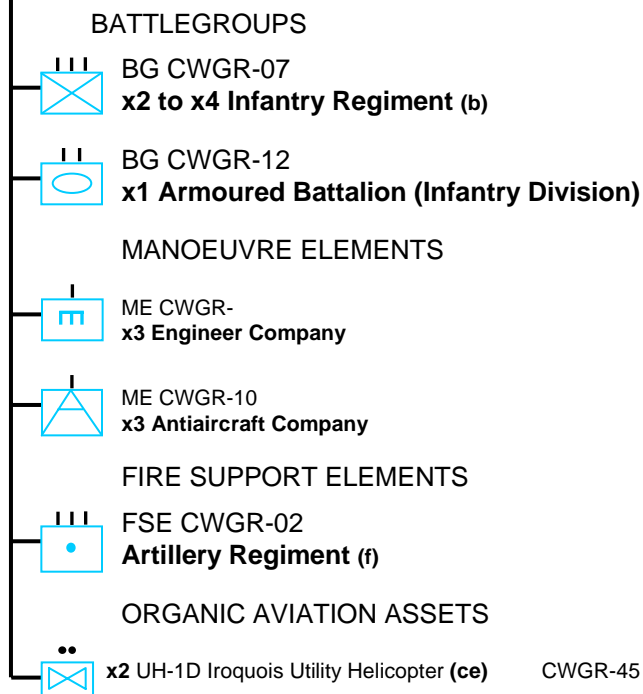

(a) The Greek Army had **x10** Infantry Divisions, plus numerous independent Infantry Brigades and small independent combined-arms commands scattered among the Greek islands. There were also 100 Home Guard Infantry Battalions, primarily concerned with coastal defence.

(b) Some divisions had **x2** or **x4** Infantry Regiments, but **x3** was the typical (and official) number of Infantry Regiments in an Infantry Division.

(c) May replace UH-1D Iroquois with:
 AB205 Utility Helicopter (Italian-built UH-1D) same card

(d) Each Greek Corps (designated A, B, C & D) had a Reconnaissance Battalion (BG CWR-14), as mentioned above. I can't find any more information, but I would imagine that each Corps would also have additional engineers and possibly air defence artillery. Artillery Brigades were also formed, though they seem to have been formed from the existing heavier divisional artillery units, rather than being entirely new units. There were also two corps-sized 'Commands' that functioned as reserve formations, but which did not contain any corps troops.

(e) The allocation of helicopters in the Greek Army & Air Force is not very clear. In 1982 the Army and Air Force had **x28** UH-1D and **x32** AB-204/205/206 between them (AB-204 is Italian (Agusta-Bell) licence-built UH-1B, AB-205 is licence built UH-1D and AB-206 is licence-built OH-58). They appear to have had a flight of **x2** helicopters in each division (listed above), which would account for **x24** helicopters. I also have a reference to the Greeks ordering a small squadron of **x4** AH-1S Cobra Attack Helicopters (CWGR-46) in 1982, but I don't know if the order was ever completed or if they then ordered more.

(f) Some divisions appear to have had only a single artillery battalion.

BATTLEGROUP CWGR-04
Greek Special Forces Division 1980s (a)

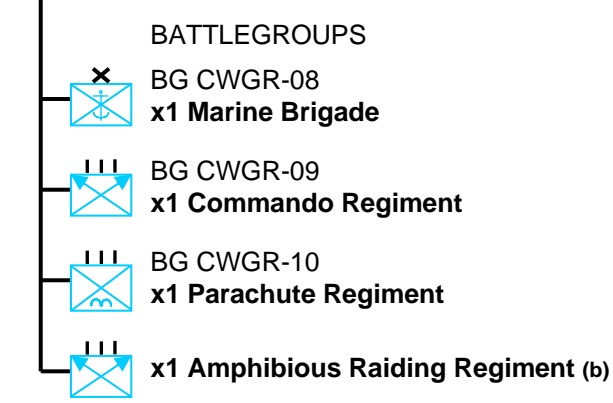

(a) The Special Forces Division was the holding formation for all Greek elite units. Special Forces would not normally feature in a BF game, but this division included all of the more 'conventional' special forces – Marines, Commandos and Paras – which is why I've included it here. Each Regiment/Brigade was organised for independent action, with organic combat support elements and there do not appear to have been any divisional troops.

(b) I don't have any information at all on the Amphibious Raiding Regiment.

BATTLEGROUP CWGR-06
Greek Mechanised Infantry Regiment 1980s

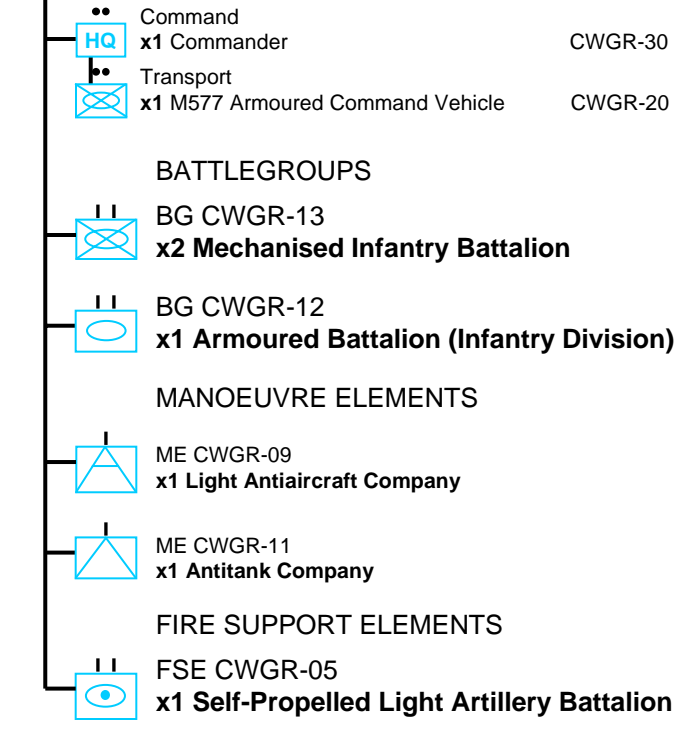

BATTLEGROUP CWGR-05
Greek Independent Armoured Brigade 1980s

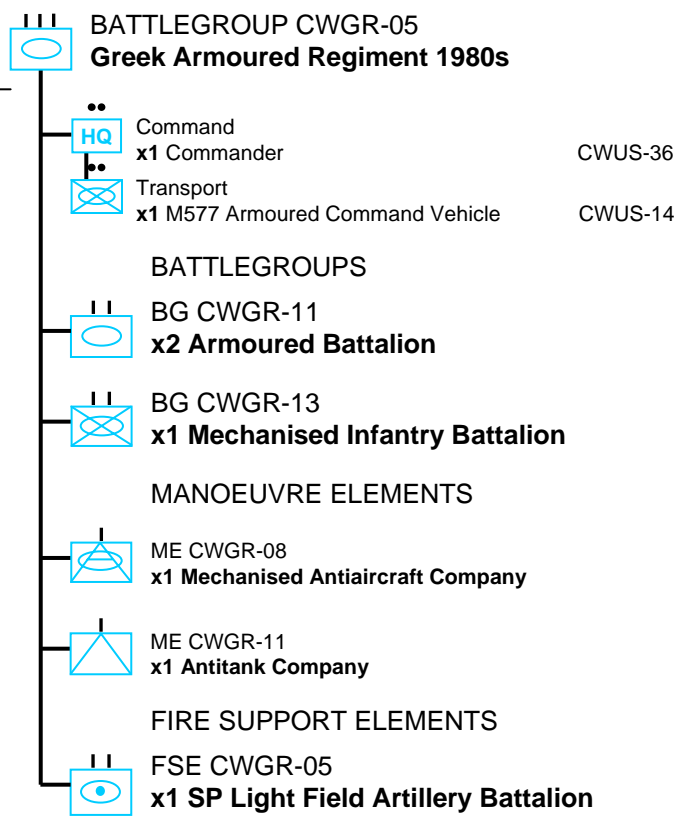

BATTLEGROUP CWGR-07
Greek Infantry Regiment 1980s

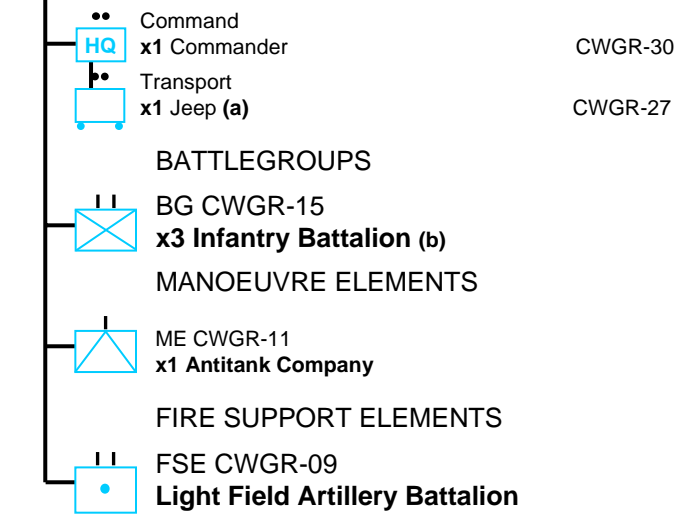

(a) The Greeks used a wide variety of Jeep-type light 4x4 vehicles; from WW2-vintage Willys Jeeps to post-war Hotchkiss Jeep copies, M151 MUTT, various types of Land Rover, Mercedes G-Wagen and others.

(b) According to one source, some regiments mechanised one of their three battalions (as per BG CWGR-12). This is entirely likely, given that in 1989 the Greek Army still had over 500x M2/M3, 400x M59 and 1,000x M113 APCs in stock, in addition to the 100x AMX-10P and 2-300x Leonidas APCs used by the Armoured formations. However, in a great many cases the Greeks were struggling to even motorise their infantry and in any case, the rugged Greek terrain often favours light infantry over mechanised forces.

 **BATTLEGROUP CWGR-08**
Greek Marine Brigade 1980s

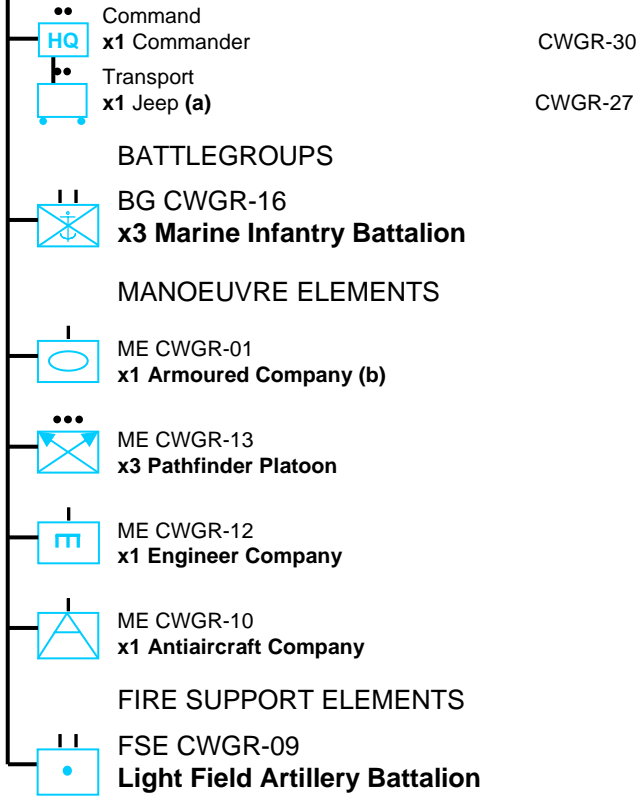

(a) The Greeks used a wide variety of Jeep-type light 4x4 vehicles; from WW2-vintage Willys Jeeps to post-war Hotchkiss Jeep copies, M151 MUTT, various types of Land Rover, Mercedes G-Wagen and others.

(b) The Marine Armoured Company was equipped with M48 tanks, which at some point during the 1980s were upgraded to M48A5.

 **BATTLEGROUP CWGR-09**
Commando Regiment

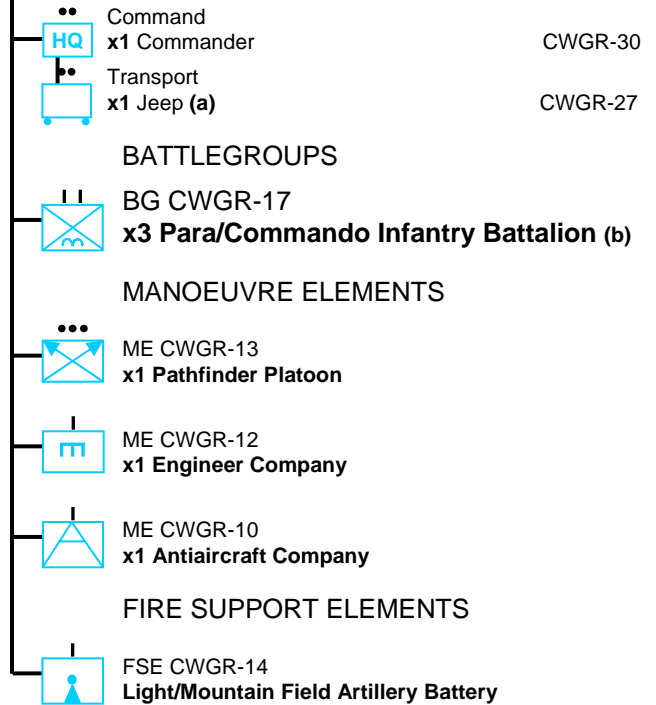

(a) The Greeks used a wide variety of Jeep-type light 4x4 vehicles; from WW2-vintage Willys Jeeps to post-war Hotchkiss Jeep copies, M151 MUTT, various types of Land Rover, Mercedes G-Wagen and others.

(b) Greek Commando and Para Battalions were organised identically (as far as game purposes go).

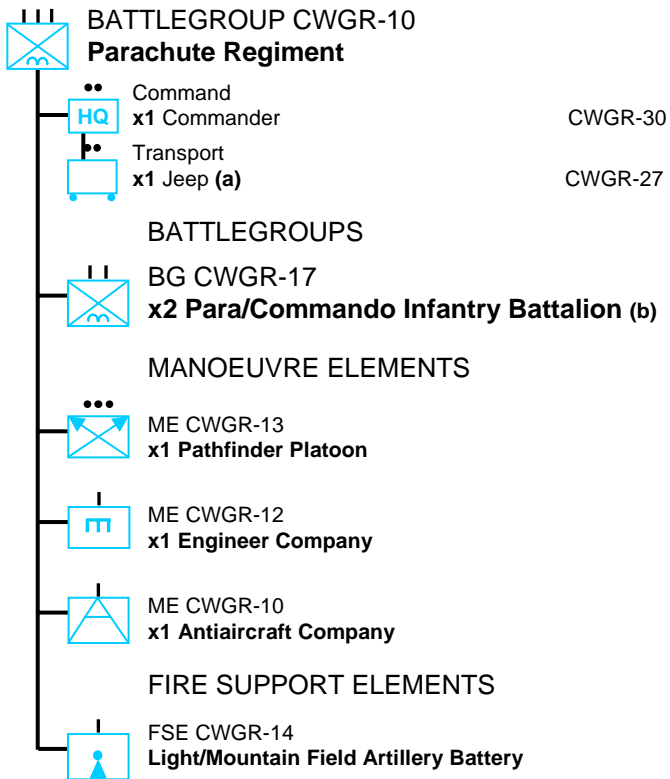

(a) The Greeks used a wide variety of Jeep-type light 4x4 vehicles; from WW2-vintage Willys Jeeps to post-war Hotchkiss Jeep copies, M151 MUTT, various types of Land Rover, Mercedes G-Wagen and others.

(b) Greek Commando and Para Battalions were organised identically (as far as game purposes go).

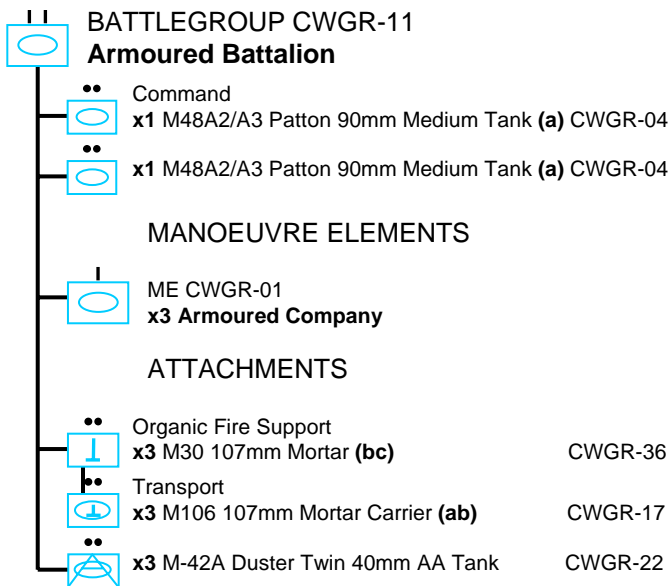
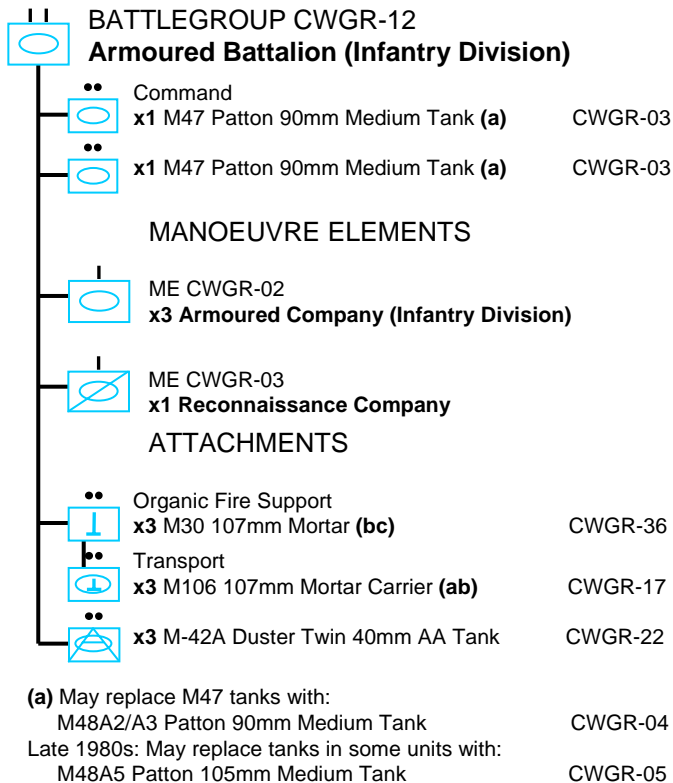

(a) M48s were used by 21st & 25th Armoured Brigades. May upgrade with:
M48A5 Patton 105mm Medium Tank CWGR-05
Alternatively, in 22nd & 23rd Armoured Brigades, replace with:
AMX-30 105mm Main Battle Tank CWGR-06
Alternatively, in 24th Armoured Brigade, replace with:
Leopard GR1 (1A3) 105mm Main Battle Tank CWGR-07

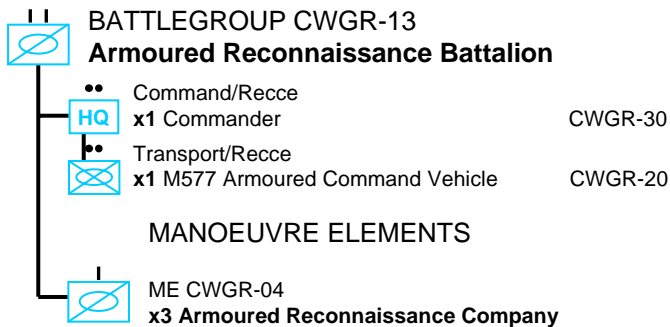

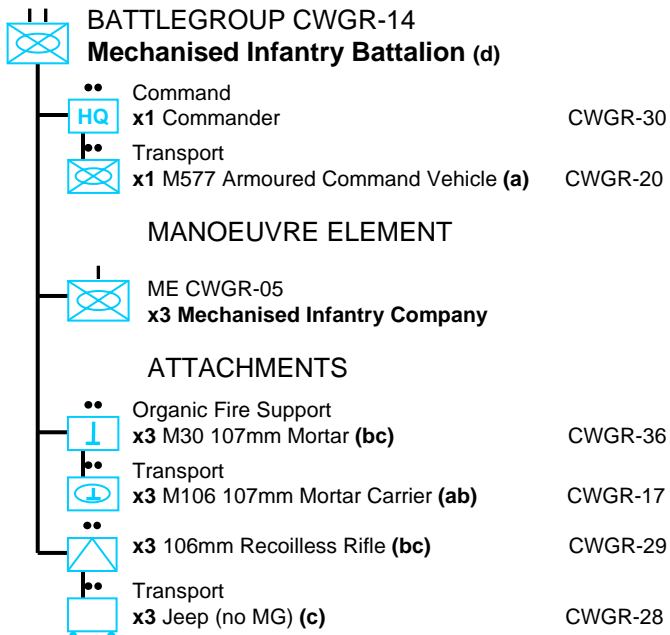

- (a)** In 22nd & 23rd Armoured Brigades: Replace all armoured vehicles with:
 AMX-10 P 20mm MICV CWGR-15
- Or in 24th Armoured Brigade with:
 Leonidas Armoured Personnel Carrier CWGR-13
- Or from 1988: in any Armoured or Mechanised Brigade, may replace with:
 Leonidas 2 Armoured Personnel Carrier CWGR-14
- Or in mechanised battalions of Infantry Regiments, may replace with:
 M2/M3 Halftrack Armoured Personnel Carrier CWGR-11
 M59 Armoured Personnel Carrier CWGR-12

(b) M30 107mm Mortar may be fired from M106 carrier when mounted. Note that the M30 may be carried in, but not fired from, a replacement carrier type such as Leonidas, M59 or M3 Halftrack.

(c) In battalions equipped with AMX-10 P MICVs, replace 107mm mortars with:
 MO-120-RT 120mm Mortar CWGR-37

Note that the MO-120-RT is a towed weapon and may not therefore be fired from its carrier like the M30 107mm mortar.

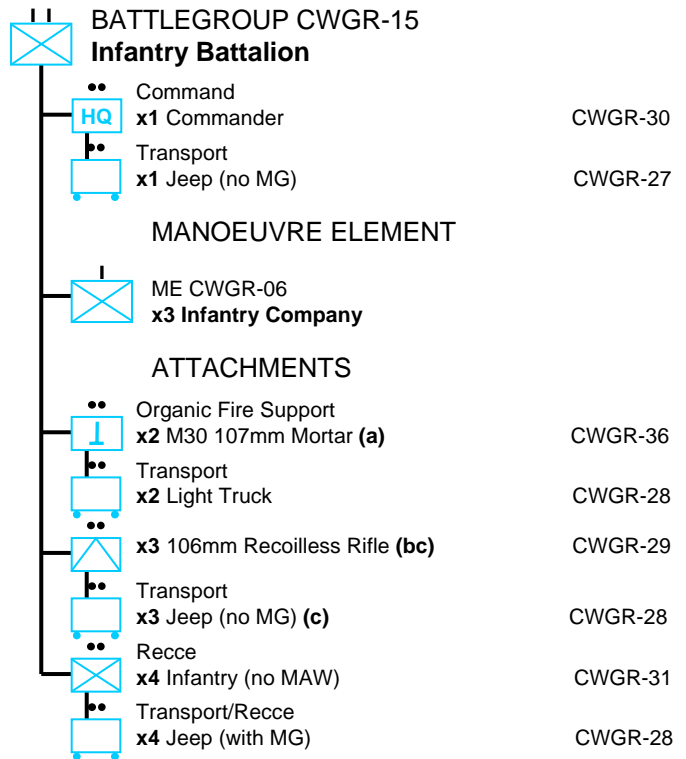

(a) May replace 107mm mortars with:
 MO-120-RT 120mm Mortar CWGR-37

(b) May replace 106mm Recoilless Rifles with:
 Milan ATGM Team (c) CWGR-42

(c) Antitank weapons may be fired from transport vehicles.

BATTLEGROUP CWGR-16
Marine Infantry Battalion

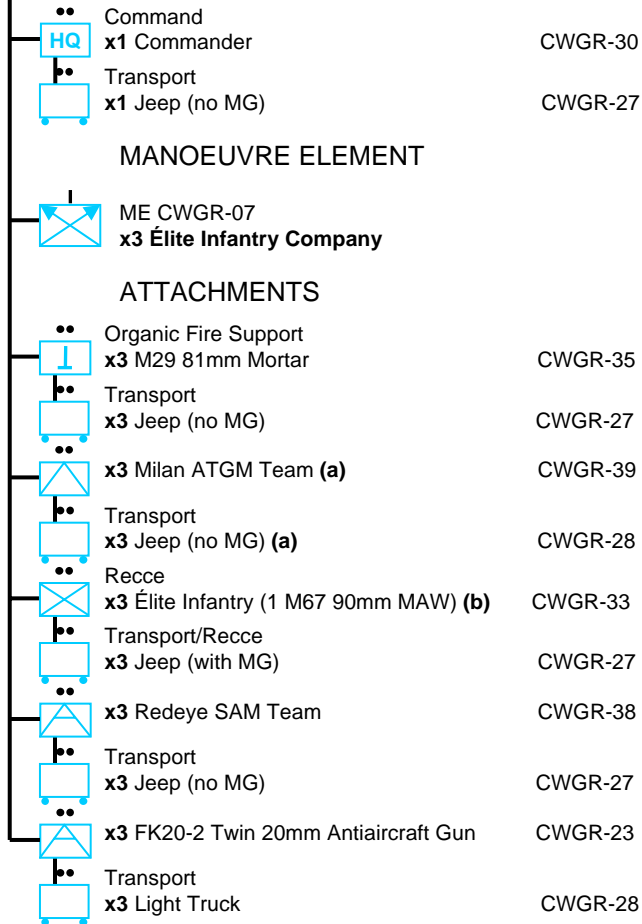

(a) Milan ATGMs may be fired from Jeeps when transported.

(b) Late 1980s: Replace M67 90mm MAW in the infantry squads with LRAC 89mm MAW. See unit card.

BATTLEGROUP CWGR-17
Para/Commando Infantry Battalion

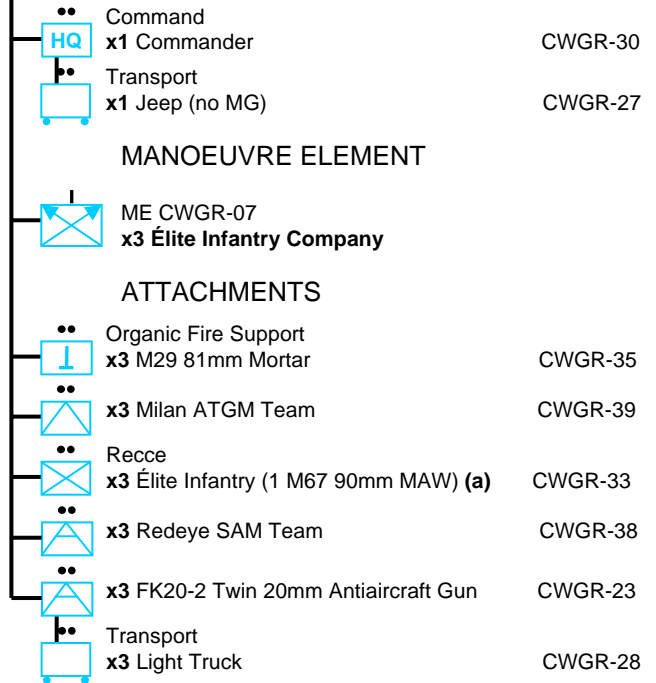

(a) Late 1980s: Replace M67 90mm MAW in the infantry squads with LRAC 89mm MAW. See unit card.

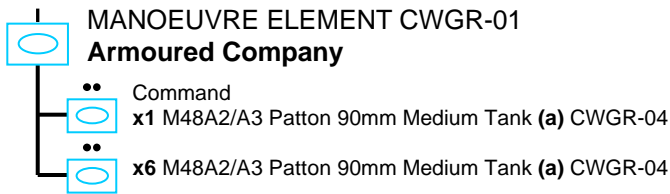

(a) M48s were used by 21st & 25th Armoured Brigades. May upgrade with:
 M48A5 Patton 105mm Medium Tank CWGR-05
 Alternatively, in 22nd & 23rd Armoured Brigades, replace with:
 AMX-30 105mm Main Battle Tank CWGR-06
 Alternatively, in 24th Armoured Brigade, replace with:
 Leopard GR1 (1A3) 105mm Main Battle Tank CWGR-07

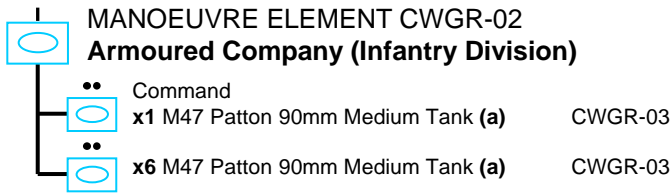

(a) May replace M47 tanks with:
 M48A2/A3 Patton 90mm Medium Tank CWGR-04
 Late 1980s: May replace tanks in some units with:
 M48A5 Patton 105mm Medium Tank CWGR-05



(a) May replace M24 Chaffee with:
 M41 Walker Bulldog 76mm Light Tank CWGR-02

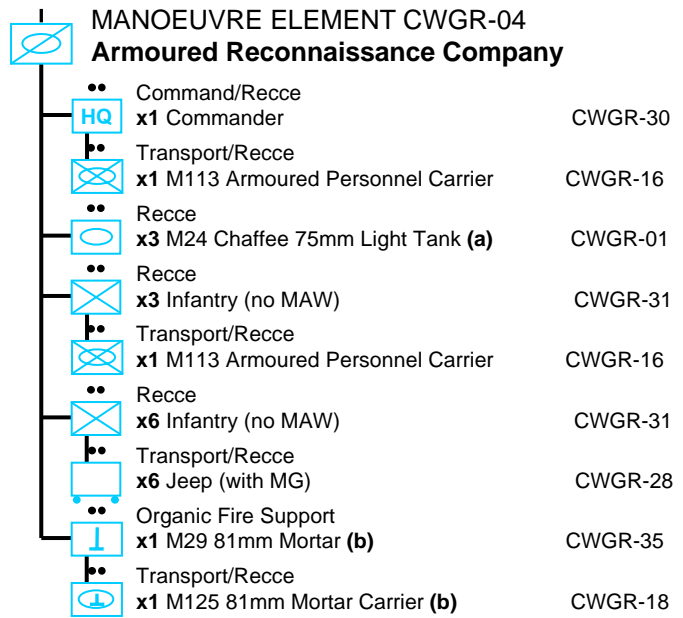

(a) May replace M24 Chaffee with:
 M41 Walker Bulldog 76mm Light Tank CWGR-02
 Or in 20th Armoured Division with:
 AMX-30 105mm Main Battle Tank CWGR-06

(b) Mortar may be fired from the M125 carrier when mounted.

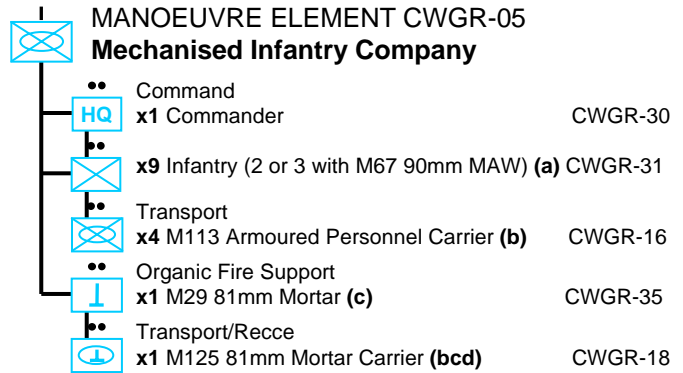

(a) May replace M67 90mm Recoilless Rifle in 20th Armoured Division with Milan ATGM. See unit card.

(b) In 22nd & 23rd Armoured Brigades: Replace M113/M125 with:
 AMX-10 P 20mm MICV CWGR-15
 Or in 24th Armoured Brigade with:
 Leonidas Armoured Personnel Carrier CWGR-13
 Or from 1988: in any Armoured or Mechanised Brigade, may replace with:
 Leonidas 2 Armoured Personnel Carrier CWGR-14
 Or in mechanised battalions of Infantry Regiments, may replace with:
 M2/M3 Halftrack Armoured Personnel Carrier CWGR-11
 M59 Armoured Personnel Carrier CWGR-12

(c) Mortar may be fired from the M125 carrier when mounted.

(d) Note that the M125 mortar carrier often seems to have been retained in units equipped with other APC types such as AMX-10 P or Leonidas.

(e) If the unit is equipped with Milan ATGMs and AMX-10 P MICVs, note that the Milans may be fired from their vehicles.

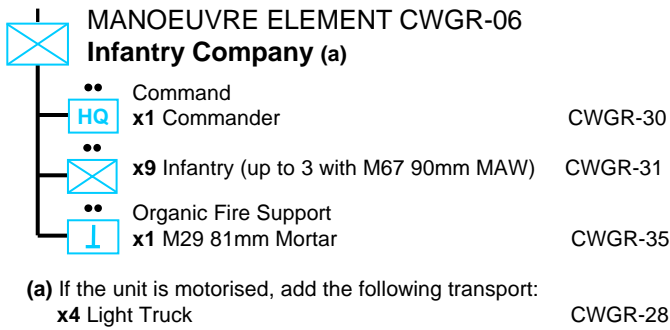

(a) Late 1980s: May replace Bofors 40mm guns in a very few units with:
 Artemis Twin 30mm Antiaircraft Gun CWGR-24

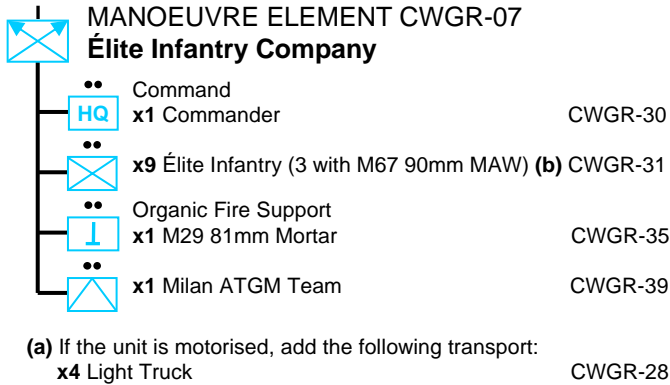

(b) Late 1980s: May replace M67 90mm MAW with LRAC 89mm MAW. See unit card.

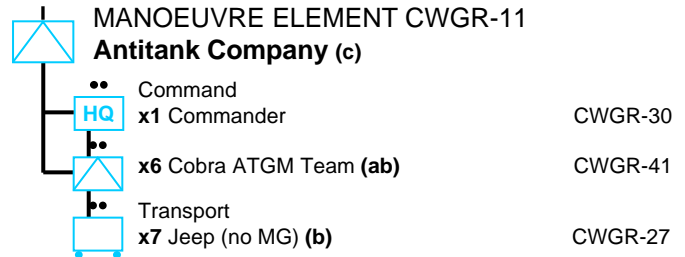

(a) May replace Cobra ATGMs with:
x6 SS-11 ATGM Team CWGR-42
 Alternatively, may replace with:
x6 M220 TOW ATGM Team CWGR-40
x6 M150 TOW ATGM Carrier CWGR-19
x1 M113 APC (Commander's transport) CWGR-16

(b) ATGMs may be fired from their vehicles when mounted.

(c) Some units did not use ATGMs at all, but instead were equipped with Tank Destroyers and organised as:

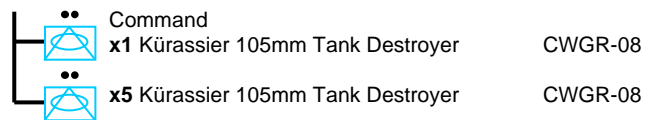
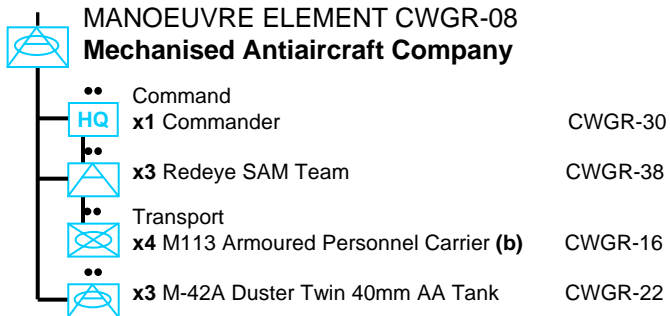

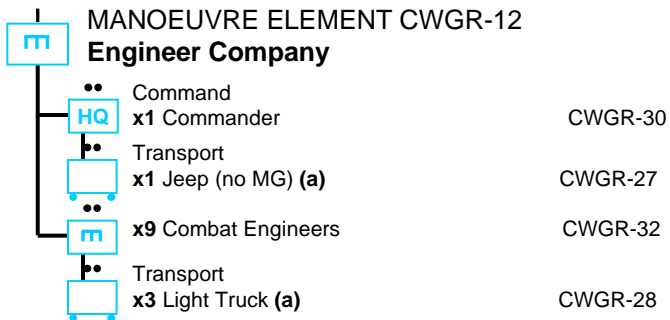

(a) I don't have any detailed information on Greek combat engineer organisation and equipment. However, they do not appear to have used heavy combat engineer vehicles such as M728 CEV, AMX-30 EBG or Centurion AVRE. While I have not come across evidence of APC use, it seems reasonable, given the very large stocks of APCs held by Greece, that the engineers attached to armoured/mechanised formations might have used APCs. May therefore replace transport with:

| | |
|--|---------|
| M2/M3 Halftrack Armoured Personnel Carrier | CWGR-11 |
| M59 Armoured Personnel Carrier | CWGR-12 |
| M113 Armoured Personnel Carrier | CWGR-16 |

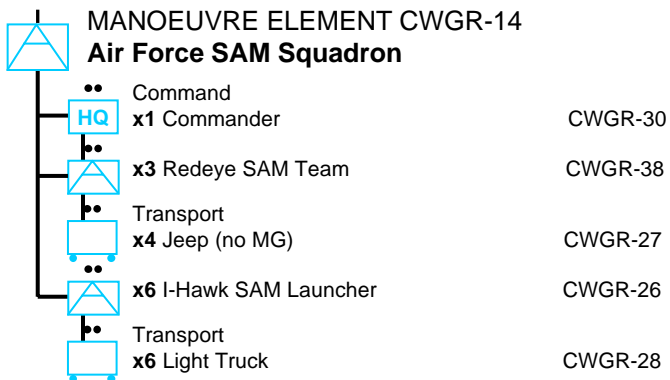
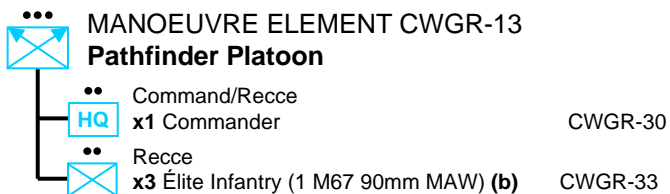

Greek Air Support Notes

The mainstay of the Hellenic Air Force's close air support effort was formed by three squadrons of A-7H Corsairs.

Greece also possessed six dual-role fighter-bomber squadrons – three each of F-5A Freedom-Fighter and F-4E Phantom. Some geriatric F-84F Thunderstreak were still in service during the early 1980s, but these were soon replaced by F-5A. Two squadrons of F-5A were converting to F-16C Fighting Falcon as the Cold War ended.

In the air defence role, Greece had two squadrons of Mirage F-1CG and four squadrons of F-104G Starfighter (two squadrons of which were converting to Mirage 2000C as the Cold War ended). These could re-rolled to fighter-bombers at a push.

Each Greek Armoured, Mechanised or Special Forces Division battalion-sized battlegroup should have a FAC attached, with an appropriate vehicle as transport. In infantry divisions, FACs would be less available – probably only available at regimental level.

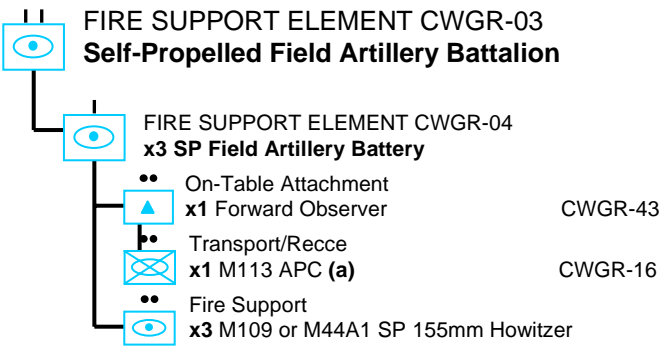
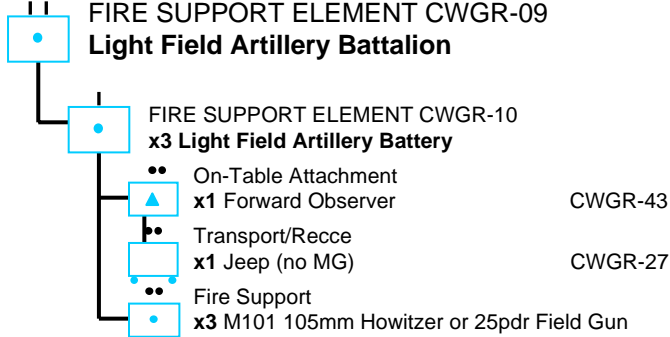
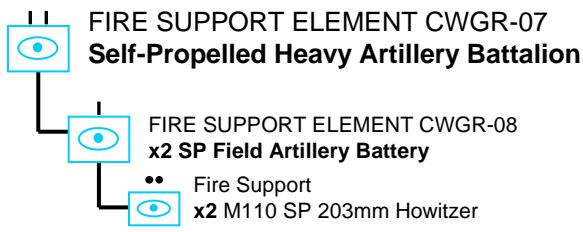
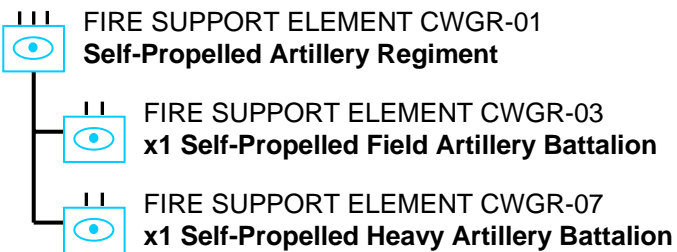

(a) May replace M113 APC with:
 M20 Armoured Reconnaissance Car CWGR-10
 M2/M3 Halftrack Armoured Personnel Carrier CWGR-11
 M59 Armoured Personnel Carrier CWGR-12

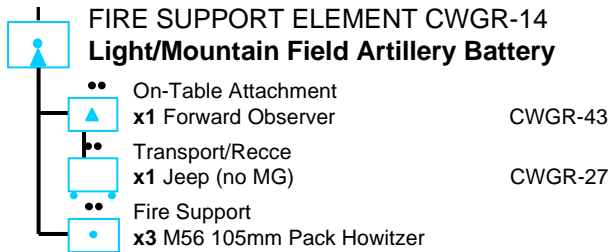
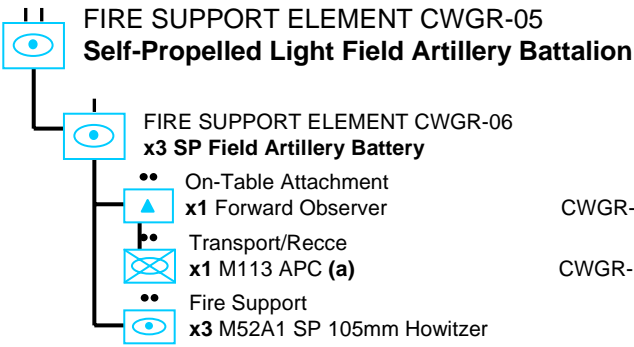

(a) May replace M113 APC with:
 M20 Armoured Reconnaissance Car CWGR-10
 M2/M3 Halftrack Armoured Personnel Carrier CWGR-11
 M59 Armoured Personnel Carrier CWGR-12

Greek Unit Cards

(Annotations indicate available 15mm or 1/100th models: 'QRF' = QRF Models/LKM Direct, 'SOG' = Skytrex/Old Glory, 'PP' = Peter Pig, 'QC' = Quality Castings/Old Glory 15s, 'BF' = Battlefront Miniatures/Flames of War)

| | |
|---|---|
| CWGR-01 – M24 Chaffee 75mm Light Tank | QRF |
| CWGR-02 – M41 Walker Bulldog 76mm Light Tank | QRF |
| CWGR-03 – M47 Patton 90mm Medium Tank | QRF |
| CWGR-04 – M48A2/A3 Patton 90mm Medium Tank | QRF, SOG |
| CWGR-05 – M48A5 Patton 105mm Medium Tank | QRF |
| CWGR-06 – AMX-30 105mm Main Battle Tank | QRF |
| CWGR-07 – Leopard GR1 (1A3) 105mm Main Battle Tank | QRF |
| CWGR-08 – Kürassier 105mm Tank Destroyer | |
| CWGR-09 – M8 Greyhound 37mm Armoured Car | SOG, BF, QRF |
| CWGR-10 – M20 Armoured Reconnaissance Car | SOG, BF, QRF |
| CWGR-11 – M2/M3 Halftrack Armoured Personnel Carrier | SOG, BF, QRF |
| CWGR-12 – M59 Armoured Personnel Carrier | QC |
| CWGR-13 – Leonidas Armoured Personnel Carrier | |
| CWGR-14 – Leonidas 2 Armoured Personnel Carrier | |
| CWGR-15 – AMX-10 P 20mm Mechanised Infantry Combat Vehicle | QRF |
| CWGR-16 – M113 Armoured Personnel Carrier | QRF, SOG, PP |
| CWGR-17 – M106 107mm Mortar Carrier | QRF |
| CWGR-18 – M125 81mm Mortar Carrier | QRF |
| CWGR-19 – M150 ATGM Vehicle (M220 TOW) | QRF, SOG |
| CWGR-20 – M577 Armoured Command Vehicle | QRF, SOG, PP |
| CWGR-21 – M48 AVLB | |
| CWGR-22 – M42A Duster Twin 40mm Antiaircraft Vehicle | QRF, QC |
| CWGR-23 – FK20-2 Twin 20mm Antiaircraft Gun | |
| CWGR-24 – Artemis Twin 30mm Antiaircraft Gun | |
| CWGR-25 – Bofors L70 40mm Antiaircraft Gun | |
| CWGR-26 – I-Hawk SAM Launcher | QC |
| CWGR-27 – Jeep | (generic card for various Jeep-type vehicles) |
| CWGR-28 – Light Truck | (generic card for various light trucks) |
| CWGR-29 – 106mm Recoilless Rifle | PP, QRF |
| CWGR-30 – Commander | |
| CWGR-31 – Infantry (M67 90mm MAW or Milan ATGM) | |
| CWGR-32 – Combat Engineers | |
| CWGR-33 – Élite Infantry (M67 90mm MAW or LRAC 89mm) | (Marines, Paras and Commandos) |
| CWGR-34 – 60mm Mortar | |
| CWGR-35 – M29 81mm Mortar | |
| CWGR-36 – M30 107mm Mortar | |
| CWGR-37 – MO-120-RT 120mm Mortar | |
| CWGR-38 – Redeye SAM Team | |
| CWGR-39 – Milan ATGM Team | QRF |
| CWGR-40 – M220 TOW Team | QRF |
| CWGR-41 – Cobra ATGM Team | |
| CWGR-42 – SS-11 ATGM Team | |
| CWGR-43 – Forward Observer | |
| CWGR-44 – AB-206 Observation Helicopter | Pocket Pak (Italian-built OH-58 Kiowa) |
| CWGR-45 – UH-1D Iroquois/AB-204/AB-205 Utility Helicopter | Revell, Corgi (AB-204 & AB-205 are Italian-built UH-1 variants) |
| CWGR-46 – AH-1S Cobra Attack Helicopter | |
| CWGR-47 – F-84F Thunderstreak Fighter-Bomber | |
| CWGR-48 – F-104G Starfighter Fighter-Bomber | Revell, Italeri, Tamiya |
| CWGR-49 – F-4E Phantom II Fighter-Bomber | Italeri, Revell, Tamiya |
| CWGR-50 – F-5A Freedom Fighter Fighter-Bomber | Italeri, Revell |
| CWGR-51 – A-7H Corsair II Light Ground-Attack Aircraft | Tamiya |
| CWGR-52 – Mirage F-1CG Fighter-Bomber | |