

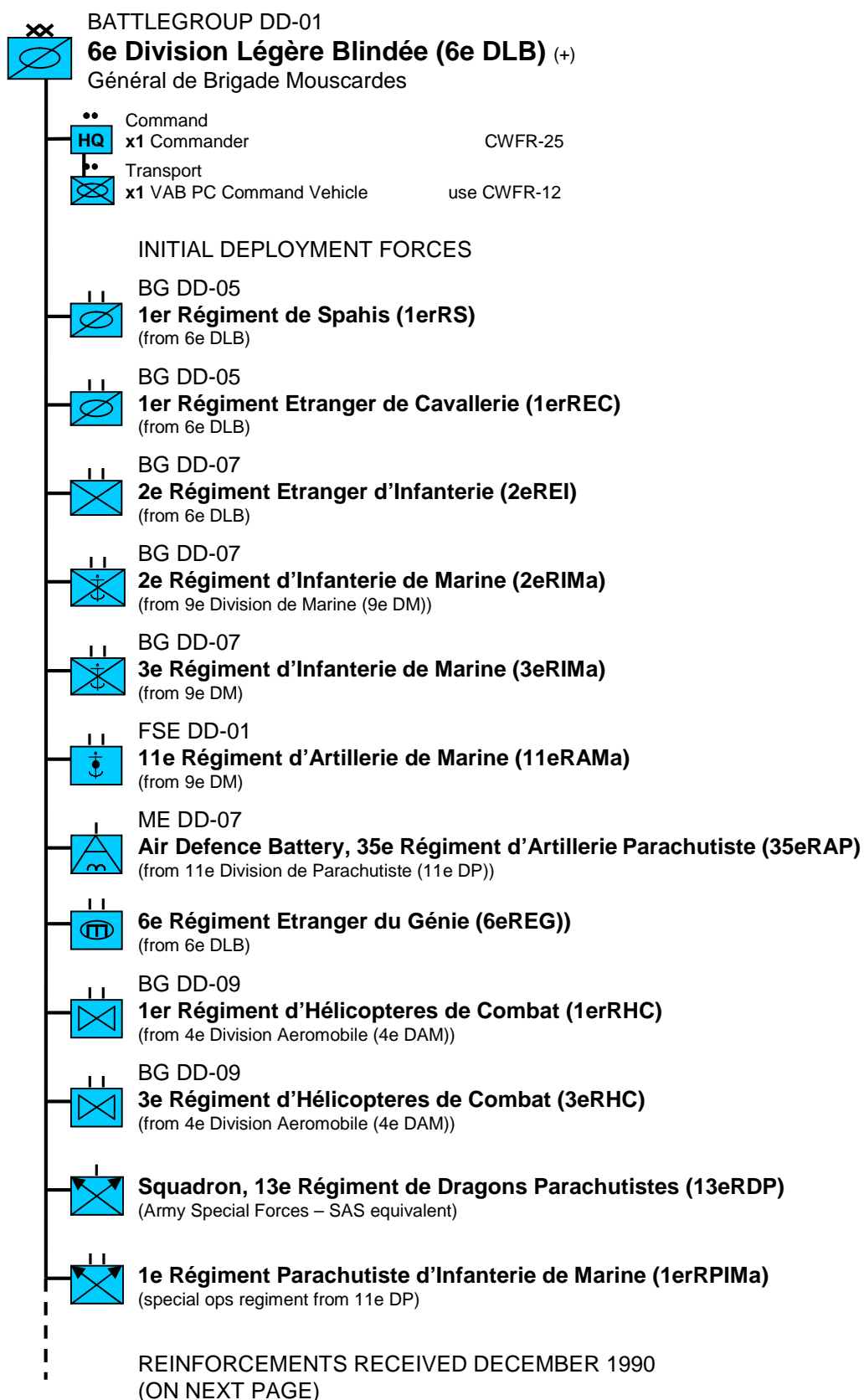







'Division Daguet'

French 6th Light Armoured Division – *6e Division Légère Blindée Français*
 During The Gulf War of 1990-91 – *Operation 'Daguet'* ('Dagger')



REINFORCEMENTS RECEIVED DECEMBER 1990

-  **ME DD-02**
x2 Squadrons, 1er Régiment de Hussards Parachutistes (1eRHP)
(from 11e DP)
-  **ME DD-03**
x2 Squadrons, Régiment de Infanterie-Chars de Marine (RICM)
(from 9e DM)
-  **ME DD-06**
x2 Companies, 1er Régiment d'Infanterie (1erRI)
(from 4e DAM)
-  **ME DD-04**
x2 Companies, 21e Régiment d'Infanterie de Marine (21eRIMa) (a)
(from 6e DLB)
-  **ME DD-04**
x2 Companies, 1er Régiment Etranger d'Infanterie (1erREI) (a)
(from 6e DLB)
-  **BG DD-08**
4e Régiment de Dragons (-)
(from 10e Division Blindée (10e DB))
-  **ME DD-01**
x1 Squadron, 503e Régiment Chars de Combat (503eRCC)
(from 10e DB)
-  **17e Régiment de Génie Parachutiste (17eRGP)**
-  **Commandos de Recherche et d'Action dans le Profondeur (CRAP)**
(Special Forces – SAS equivalent)

6e DLB Reorganised For Operation 'Desert Sabre' 1991

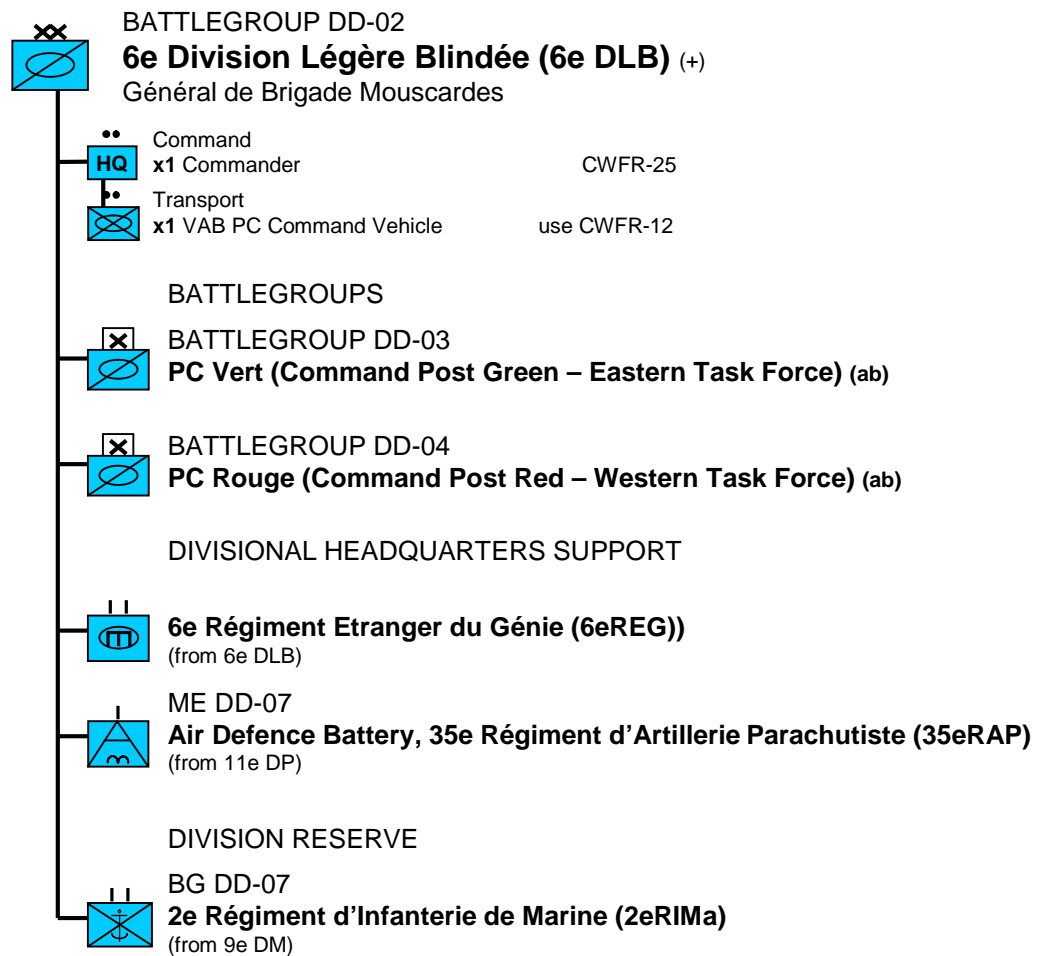

(a) There was no formal Brigade or multi-battalion Regiment organisation in the French Army following the 1976 reforms (though the French changed again in 2002 to using Brigades as the basic formation, while abolishing Divisions and Corps). These Task Forces were therefore ad hoc command structures, made necessary by the rapid expansion of 6e DLB from a six-regiment formation to the equivalent of sixteen regiments! I don't have any information on who commanded these Task Forces, nor how the HQs were formed and organised. My best guess is that additional HQ & Staff elements were sent to 6e DLB from other formations in *Force d'Action Rapide* – France's rapid-reaction corps, of which 6e DLB was a part.

(b) 6e DLB was placed under the command of US XVIII (Airborne) Corps for Operation Desert Sabre, and operated alongside US 82nd Airborne Division on the extreme left flank of the operation. The division penetrated 100 miles into Iraq and secured Al-Salman airbase. Various units from 82nd Airborne Division and XVIII (Airborne) Corps were placed under the division's command at various times – the first time that US units had been under French command for over half a century.

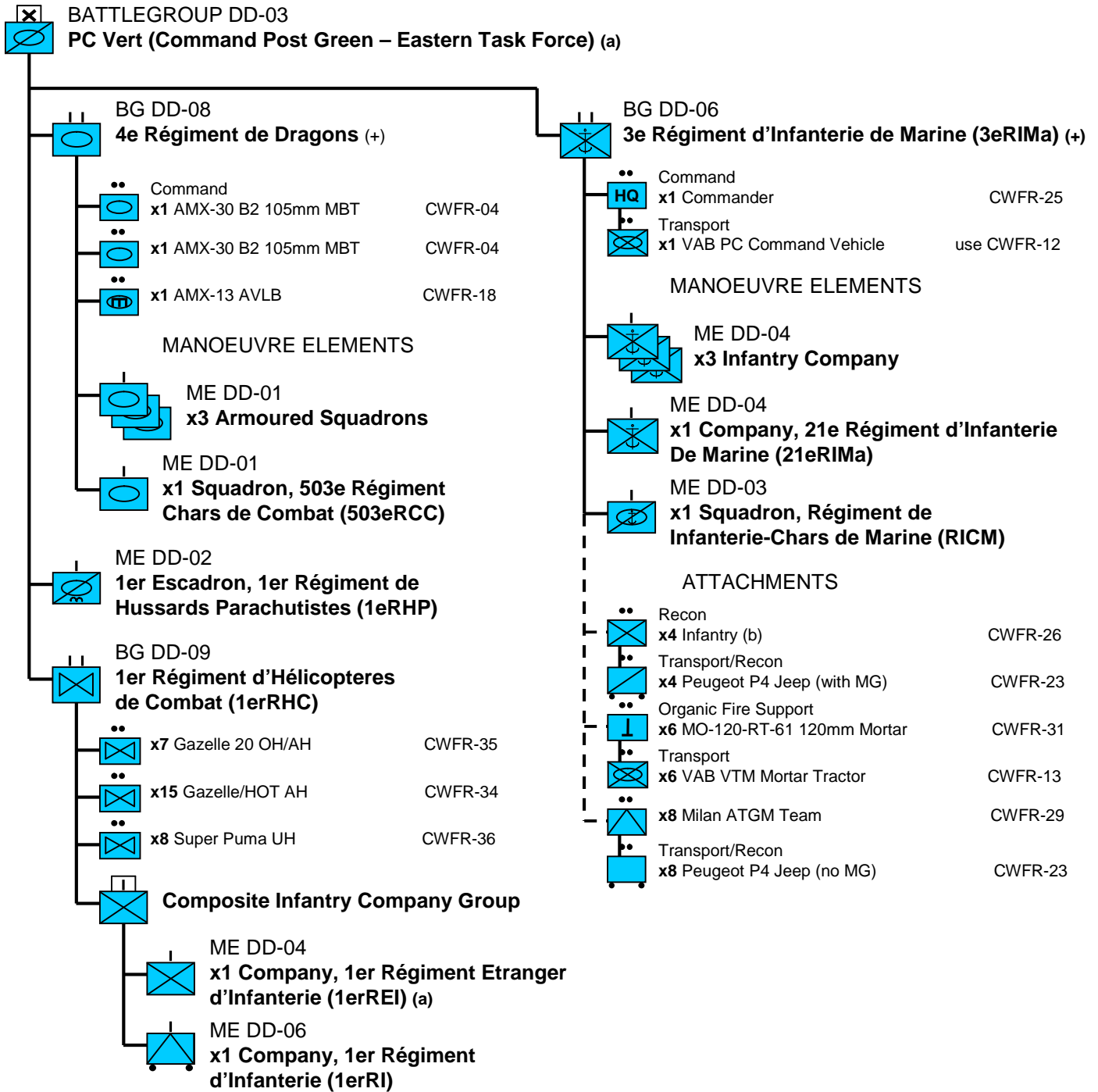

(a) PC Vert was supported by 1st Brigade, US 82nd Airborne Division and two battalions of the US 18th Field Artillery Brigade (Airborne) to its initial objectives. The US artillery battalions each had three batteries, each with x3 M198 Towed 155mm Guns.

BATTLEGROUP DD-04
PC Rouge (Command Post Red – Western Task Force)

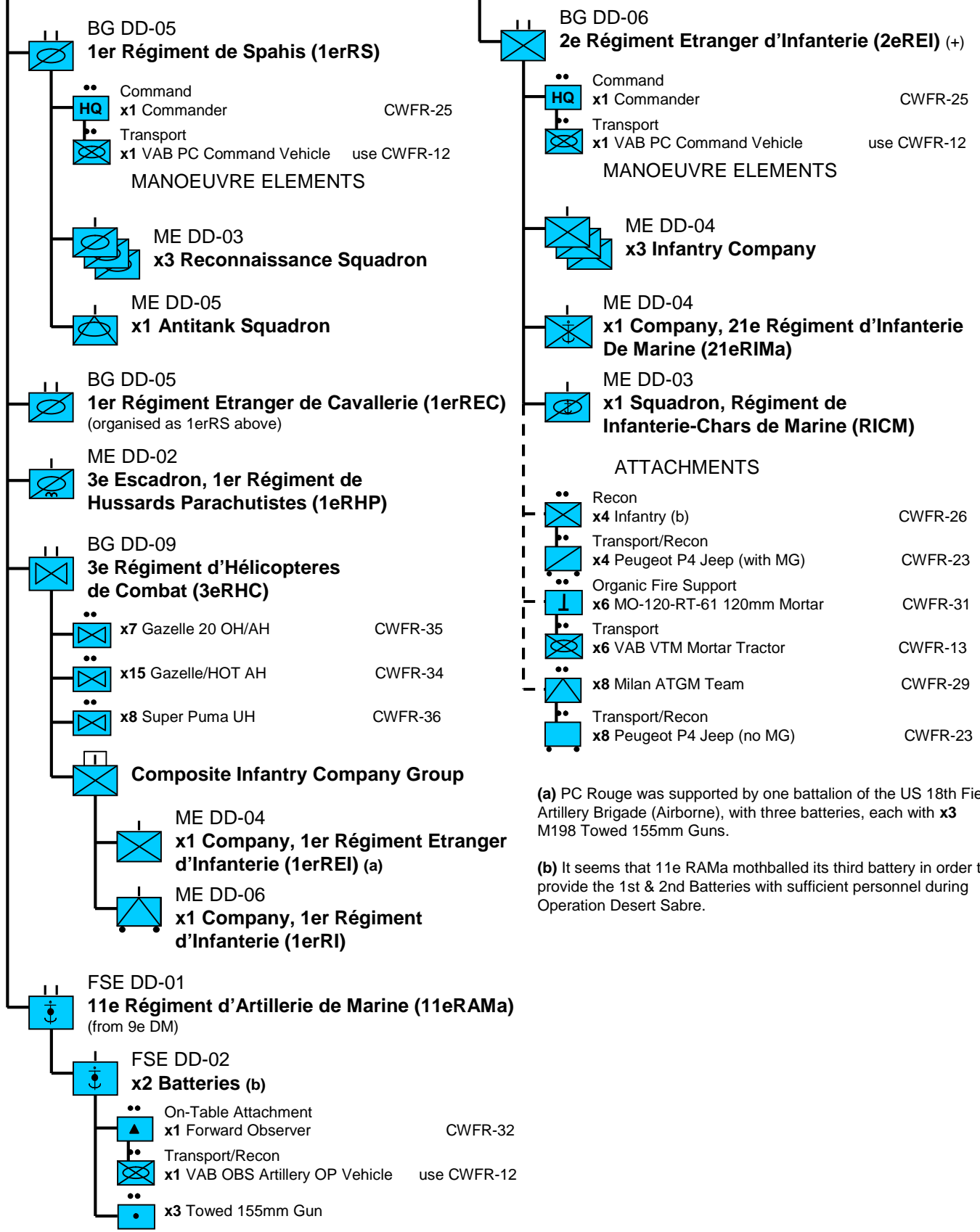

(a) PC Rouge was supported by one battalion of the US 18th Field Artillery Brigade (Airborne), with three batteries, each with x3 M198 Towed 155mm Guns.

(b) It seems that 11e RAMa mothballed its third battery in order to provide the 1st & 2nd Batteries with sufficient personnel during Operation Desert Sabre.

Division Reserve During Operation Desert Sabre

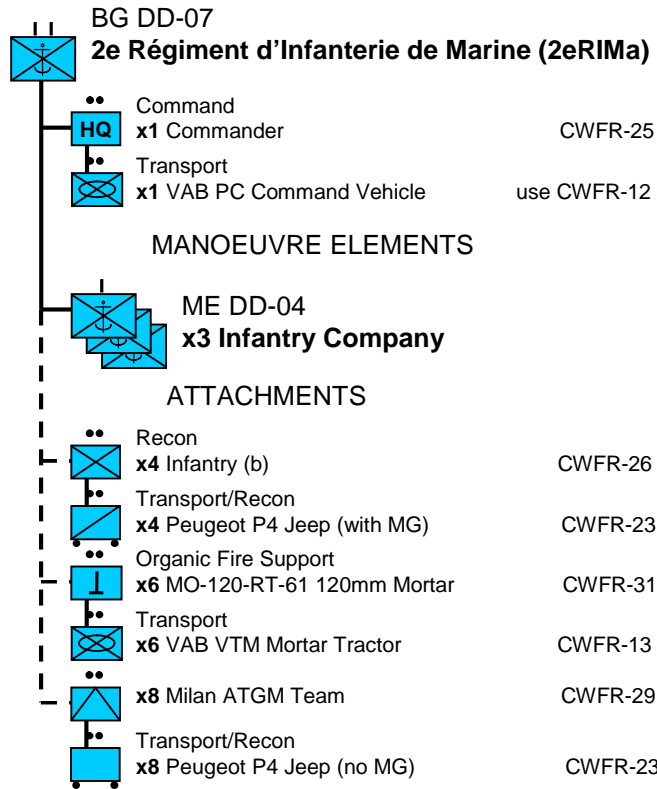

Division 'Daguet' Manoeuvre Elements

