

(a) Major General C Maltby, GOC Hong Kong Fortress, initially divided his forces into two brigades, divided geographically into Mainland Brigade, defending Kowloon, the New Territories and the 'Gin Drinkers' Line', and 'Island Brigade', defending Hong Kong Island. When the keystone of the defences, the Shing Mun Redoubt, fell with hardly a whimper on 9th December, the Mainland Brigade was soon out-manoeuvered and was evacuated to Hong Kong Island on 12th December. Maltby then reorganised his forces into Eastern and Western Brigades.

BG-BRHK02

# Western Brigade

Brigadier J Lawson



## BATTLEGROUPS

BG-BRHK04

**2nd Battalion, The Royal Scots**  
Lieutenant Colonel S White

BG-BRHK06

**2nd Battalion, 14th Punjab Regiment**  
Lieutenant Colonel G Kidd

BG-BRHK08

**1st Battalion, The Winnipeg Grenadiers**  
Lieutenant Colonel JLR Sutcliffe

BG-BRHK02

(-) **1st Battalion, The Middlesex Regiment**  
Lieutenant Colonel HWM Stewart (a)

## ELEMENTS, HONG KONG VOLUNTEER DEFENCE CORPS:

ME-BRHK06

**3 (Eurasian) Company, HKVDC**  
Major EG Stewart

ME-BRHK05

**4 (Chinese) Company, HKVDC**

ME-BRHK05

**5 (Portuguese) Company, HKVDC**

ME-BRHK05

**7 Company, HKVDC**

**3 (Coastal) Battery, HKVDC**  
(Ap Lei Chau Island)

ME-BRHK12

**Engineer Field Company, HKVDC**  
Captain KS Robertson

ME-BRHK08

**Armoured Car Platoon, HKVDC**  
Lieutenant MG Carruthers

ME-BRHK09

**Recce Platoon, HKVDC**  
Lieutenant R Edwards

ME-BRHK11

**2 ('Hugheseliers') Ind Plt, HKVDC**  
Major Paterson

## ATTACHED ELEMENTS FROM:

**Motor Machine Gun Platoon, HKVDC**  
Captain John Wray

## ELEMENTS, HONG KONG & SINGAPORE ROYAL ARTILLERY:

**12 Coastal Regiment, HKSRA**

ME-BRHK15

**17 Heavy Anti-Aircraft Battery, HKSRA**  
Lieutenant FH Fairclough

FSE-BRHK01

**2 Mountain Battery, HKSRA**

FSE-BRHK02

**4 Medium Battery, HKSRA**

FSE-BRHK02

**25 Medium Battery, HKSRA**

ATTACHED ELEMENTS FROM:  
**965 Defence Battery, HKSRA**

## OTHER ELEMENTS

ME-BRHK16

**22 Fortress Field Company, Royal Engineers**

ME-BRHK16

**40 Fortress Field Company, Royal Engineers**

ME-BRHK17

**Royal Marine Detachment, HMS Tamar**  
Major C Farrington

ME-BRHK17

**Royal Naval Detachment, HMS Thracian**  
Commander AL Pears

ME-BRHK18

**Hong Kong Dockyard Defence Corps (HKDDC)**  
Major D Campbell

(a) After the withdrawal to Hong Kong Island, following the fall of the 'Gin Drinkers' Line', the Hong Kong Garrison was reorganised into two new brigades; Western Brigade and Eastern Brigade.

(b) HQ, A, C & Z Companies only.

BG-BRHK03

**Eastern Brigade**  
Brigadier C Wallis



**BATTLEGROUPS**

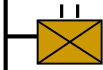

BG-BRHK07  
**5th Battalion, 7th Rajput Regiment**  
Lieutenant Colonel J Cadogan-Rawlinson

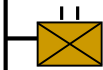

BG-BRHK09  
**1st Battalion, The Royal Rifles Of Canada**  
Lieutenant Colonel WJ Home

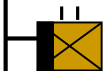

ELEMENTS FROM BG-BRHK02  
(-) **1st Battalion, The Middlesex Regiment**  
Lieutenant Colonel HWM Stewart (a)

**ELEMENTS, HONG KONG VOLUNTEER DEFENCE CORPS:**

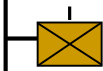

ME-BRHK05  
**1 Company, HKVDC**  
Captain AH Penn

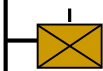

ME-BRHK05  
**2 (Scottish) Company, HKVDC**  
Major HR Forsyth

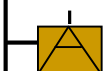

ME-BRHK07  
**6 (Portuguese (AA)) Company, HKVDC**

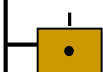

**1 (Coastal) Battery, HKVDC**  
(D'Aguillar)

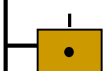

**2 (Coastal) Battery, HKVDC**  
(Bluff Head)

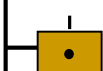

**4 (Coastal) Battery, HKVDC**  
(Pak Sha Wan)

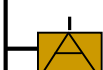

ME-BRHK13  
**5 (Anti-Aircraft) Battery, HKVDC**  
(Sai Wan)

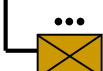

ME-BRHK10  
**1 (Stanley) Ind Plt, HKVDC**  
Lieutenant Fitzgerald

**ELEMENTS, HONG KONG & SINGAPORE ROYAL ARTILLERY:**

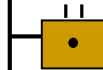

**8 Coastal Regiment, HKSRA**

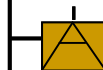

ME-BRHK15  
**7 Anti-Aircraft Battery, HKSRA**

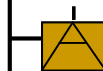

ME-BRHK15  
**18 Anti-Aircraft Battery, HKSRA**

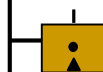

FSE-BRHK01  
**1 Mountain Battery, HKSRA**

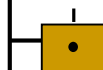

FSE-BRHK02  
**3 Medium Battery, HKSRA**

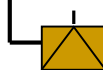

ATTACHED ELEMENTS FROM:  
**965 Defence Battery, HKSRA**

(a) After the withdrawal to Hong Kong Island, following the fall of the 'Gin Drinkers' Line', the Hong Kong Garrison was reorganised into two new brigades; Western Brigade and Eastern Brigade.

(b) B & D Companies only.

BG-BRHK04

## 2nd Battalion, The Royal Scots Lieutenant Colonel S White

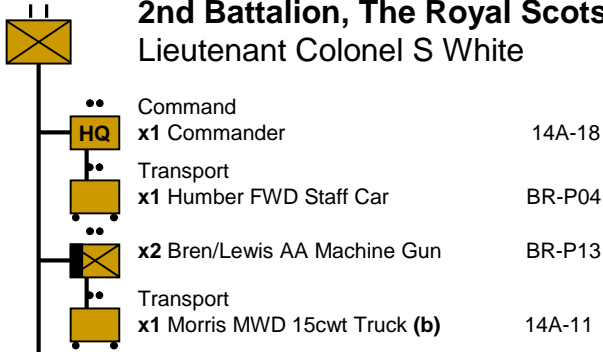

### MANOEUVRE ELEMENTS

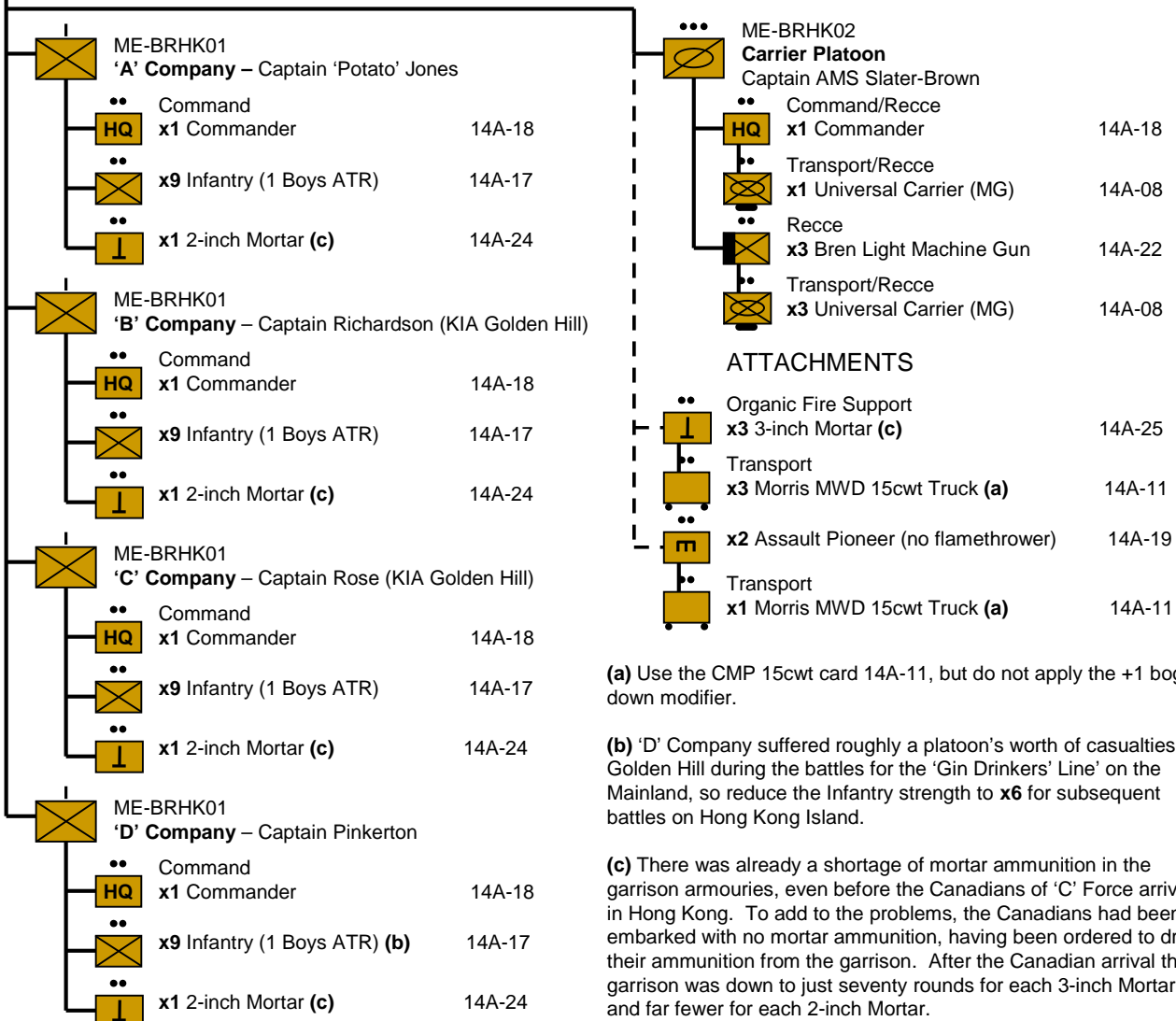

**(a)** Use the CMP 15cwt card 14A-11, but do not apply the +1 bog-down modifier.

**(b)** 'D' Company suffered roughly a platoon's worth of casualties at Golden Hill during the battles for the 'Gin Drinkers' Line' on the Mainland, so reduce the Infantry strength to **x6** for subsequent battles on Hong Kong Island.

**(c)** There was already a shortage of mortar ammunition in the garrison armouries, even before the Canadians of 'C' Force arrived in Hong Kong. To add to the problems, the Canadians had been embarked with no mortar ammunition, having been ordered to draw their ammunition from the garrison. After the Canadian arrival the garrison was down to just seventy rounds for each 3-inch Mortar and far fewer for each 2-inch Mortar.

**(d)** The Royal Scots suffered a severe crisis of confidence and leadership during the Gin Drinkers' Line battles, particularly in the immediate aftermath of the loss of the Shin Mung Redoubt. Therefore I would class them as 'Raw' for this part of the campaign. Once they had been evacuated to Hong Kong Island they seemed to recover their form and fought extremely hard. Therefore class as 'Trained' for the island battles.

BG-BRHK05

# 1st (MG) Battalion, The Middlesex Regiment

Lieutenant Colonel HWM Stewart

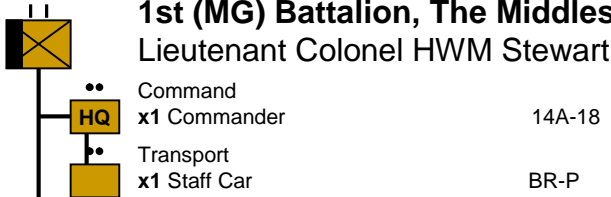

## MANOEUVRE ELEMENTS

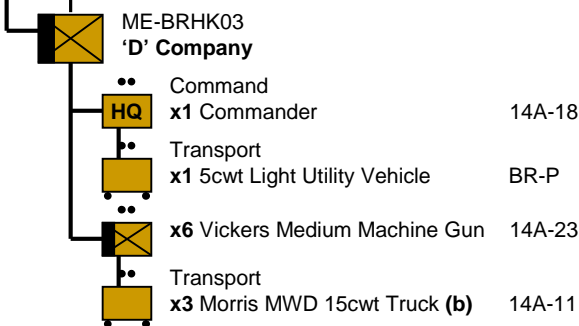
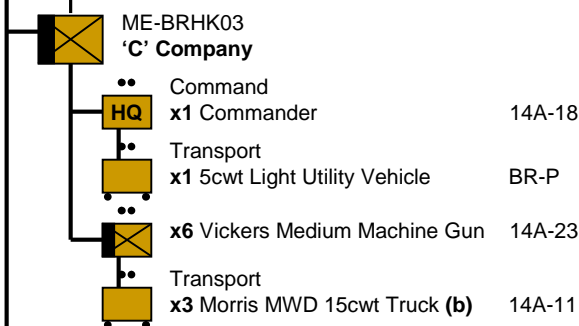
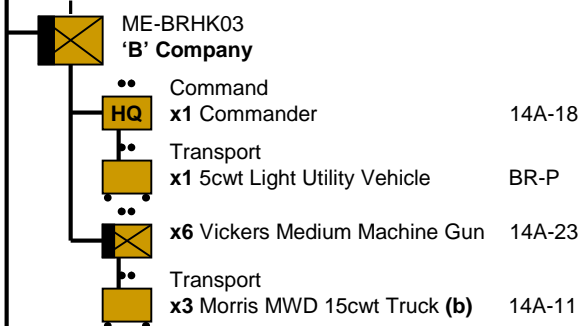
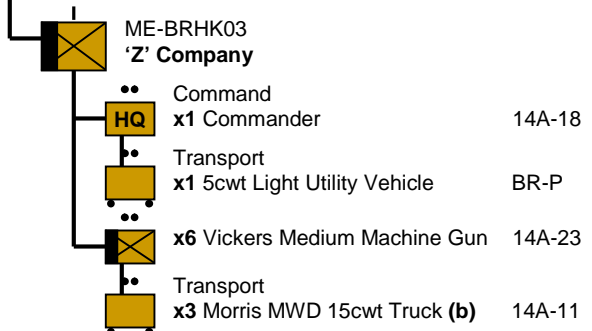
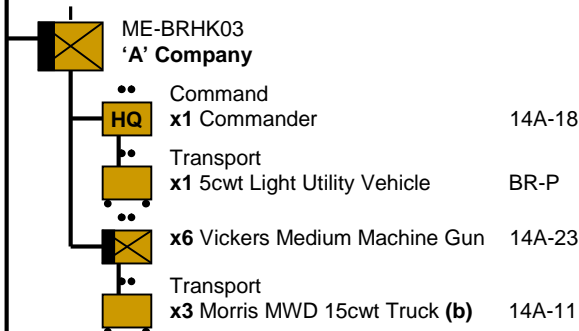

(a) Unlike MG Battalions in other theatres and periods of WW2, the 1st Middlesex at Hong Kong was not split up as individual platoon attachments to infantry battalions. Each company of the 1st Middlesex fought as an integral whole and were often found fighting on when their supporting infantry battalions had pulled back. The battalion was initially split in half, divided between Eastern and Western Brigades, holding the line of pillboxes along the northern shore of Hong Kong Island, losing many men as the pillboxes drew the attentions of Japanese artillery firing from Kowloon over open sights. Once the Japanese had gained a bridgehead, the Middlesex fell back to the west. Its machine guns fired over a million rounds, inflicting hundreds of casualties on the invaders and preventing them from breaking Western Brigade's line, often fighting on alone as at Leighton Hill.

(b) It is possible that, given its static defence role, the 1st Middlesex did not have the full allocation of motor transport shown here. However, if using trucks, use the CMP 15cwt card 14A-11, but do not apply the +1 bog-down modifier.

BG-BRHK06

## 2nd Battalion, 14th Punjab Regiment

Lieutenant Colonel G Kidd

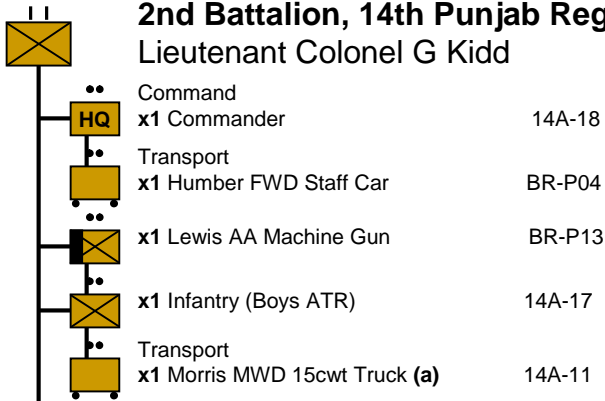

### MANOEUVRE ELEMENTS

### ATTACHMENTS

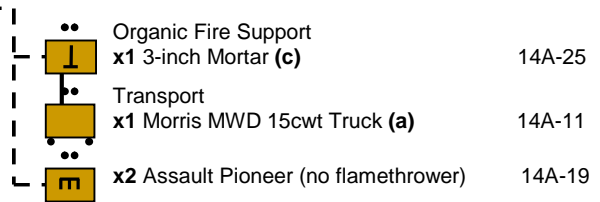
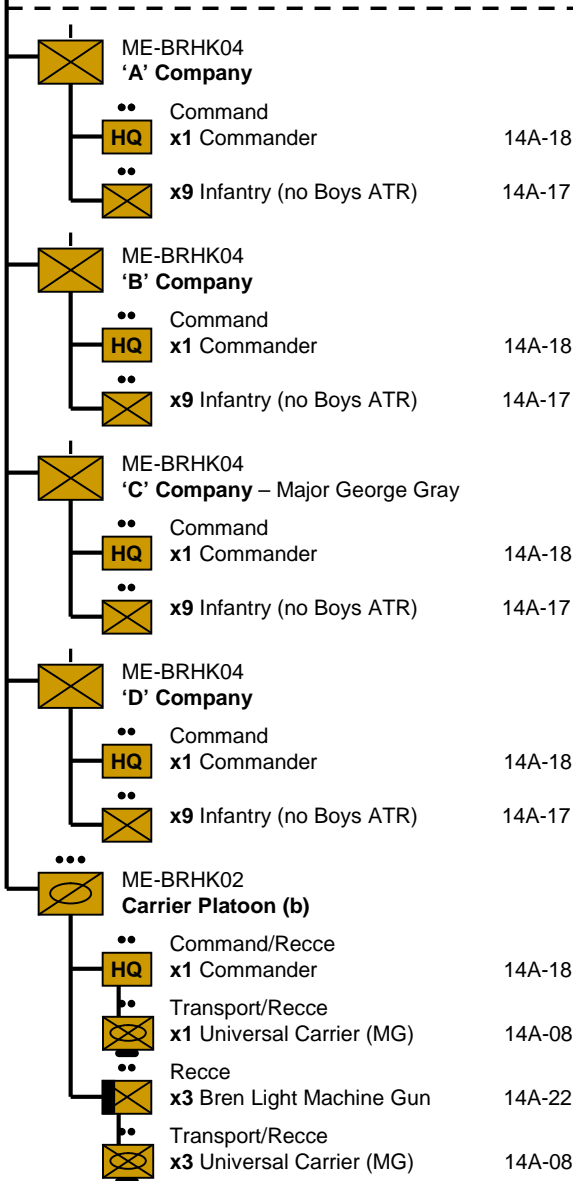

(a) Use the CMP 15cwt card 14A-11, but do not apply the +1 bog-down modifier.

(b) The allocation of Carrier Platoons to 'Garrison Establishment' Indian infantry battalions was variable. Although I can't find an order of battle for the Indian battalions in Hong Kong which specifically lists Carrier Platoons, I have found two references to suggest they were present. The first is a reference to a Lieutenant Kerfoot of the 2/14th Punjabis, leading a Carrier-mounted attack in the latter stages of the campaign. The second is a Japanese report by Colonel Doi which describes being 'plagued by Carriers' during the landings against the 5/7th Rajputs and bemoaning the loss of all but one gun from his regimental Antitank Company. The 2nd Royal Scots and the HKVDC both definitely had Carrier Platoons, but these were all in Western Brigade, so could not therefore have provided the Carriers supporting the Rajputs. I therefore think that there is sufficient evidence to warrant the inclusion of Carriers here.

(c) There was already a shortage of mortar ammunition in the garrison armouries, even before the Canadians of 'C' Force arrived in Hong Kong. To add to the problems, the Canadians had been embarked with no mortar ammunition, having been ordered to draw their ammunition from the garrison. After the Canadian arrival the garrison was down to just seventy rounds for each 3-inch Mortar and far fewer for each 2-inch Mortar.

BG-BRHK07

## 5th Battalion, 7th Rajput Regiment

Lieutenant Colonel J Cadogan-Rawlinson

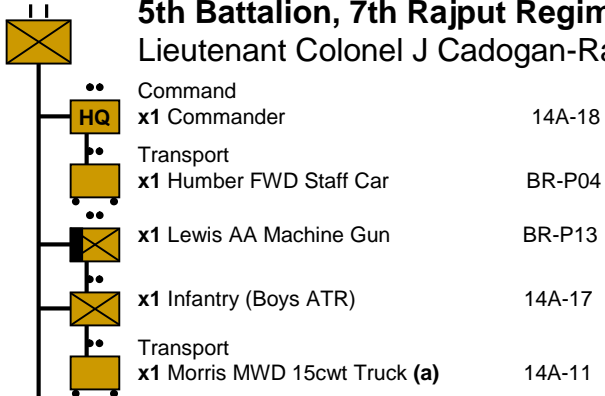

### MANOEUVRE ELEMENTS

### ATTACHMENTS

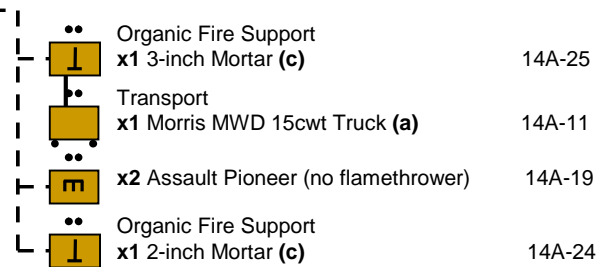
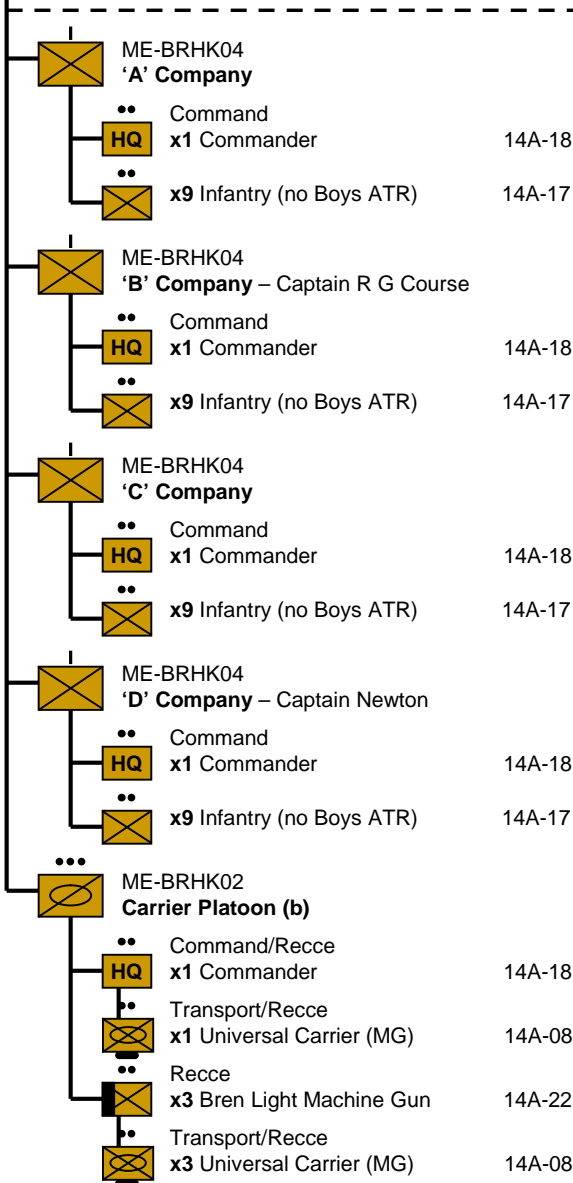

(a) Use the CMP 15cwt card 14A-11, but do not apply the +1 bog-down modifier.

(b) The allocation of Carrier Platoons to 'Garrison Establishment' Indian infantry battalions was variable. Although I can't find an order of battle for the Indian battalions in Hong Kong which specifically lists Carrier Platoons, I have found two references to suggest they were present. The first is a reference to a Lieutenant Kerfoot of the 2/14th Punjabis, leading a Carrier-mounted attack in the latter stages of the campaign. The second is a Japanese report by Colonel Doi which describes being 'plagued by Carriers' during the landings against the 5/7th Rajputs and bemoaning the loss of all but one gun from his regimental Antitank Company. The 2nd Royal Scots and the HKVDC both definitely had Carrier Platoons, but these were all in Western Brigade, so could not therefore have provided the Carriers supporting the Rajputs. I therefore think that there is sufficient evidence to warrant the inclusion of Carriers here.

(c) There was already a shortage of mortar ammunition in the garrison armouries, even before the Canadians of 'C' Force arrived in Hong Kong. To add to the problems, the Canadians had been embarked with no mortar ammunition, having been ordered to draw their ammunition from the garrison. After the Canadian arrival the garrison was down to just seventy rounds for each 3-inch Mortar and far fewer for each 2-inch Mortar.

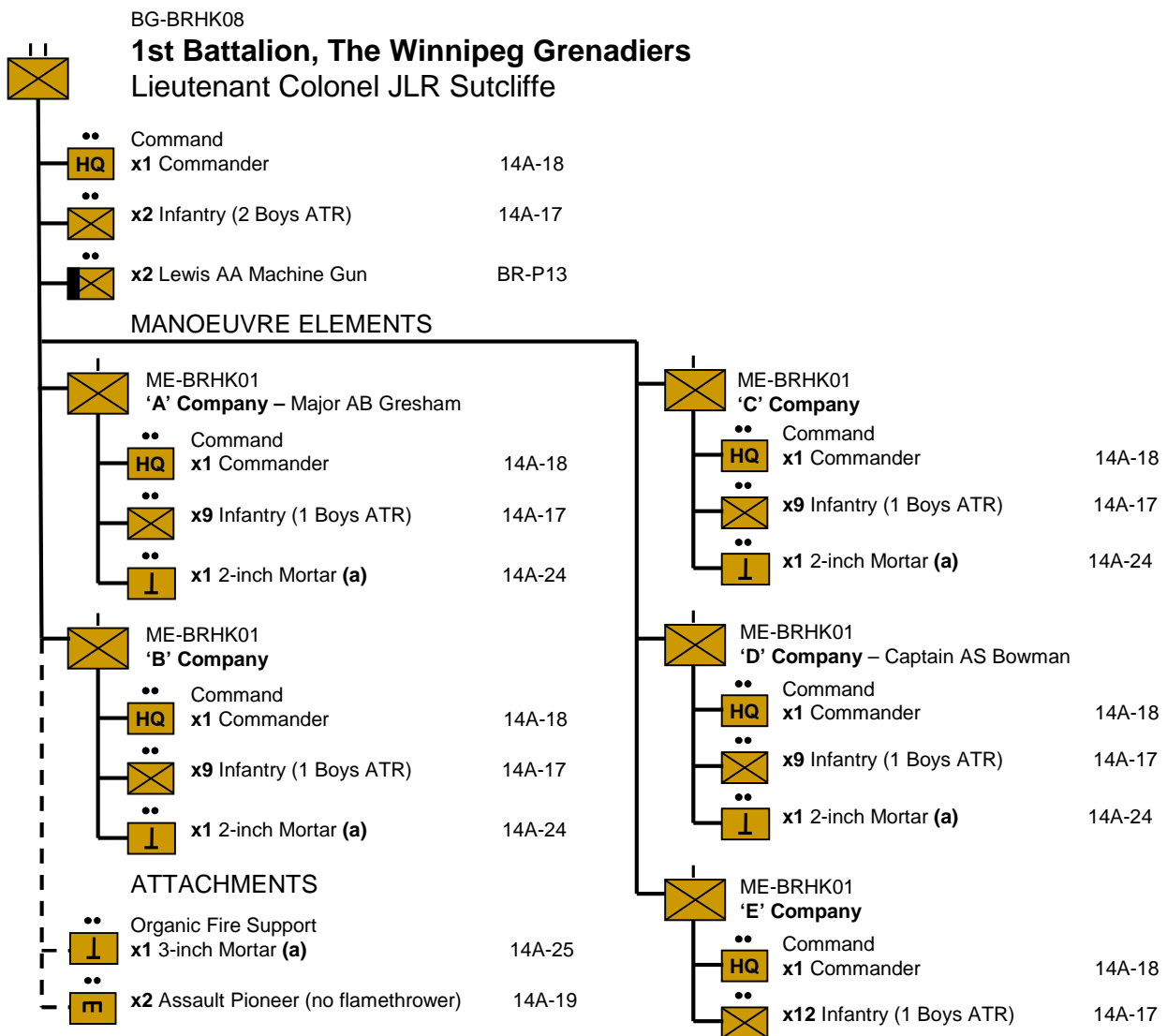

(a) There was already a shortage of mortar ammunition in the garrison armouries, even before the Canadians of 'C' Force arrived in Hong Kong. To add to the problems, the Canadians had been embarked with no mortar ammunition, having been ordered to draw their ammunition from the garrison. After the Canadian arrival the garrison was down to just seventy rounds for each 3-inch Mortar and far fewer for each 2-inch Mortar. The Canadian motor transport, including Carriers, ended up in the Phillipines, where it was used by US and Filipino forces.

(b) 'C' Force received its first-wave of reinforcements before embarkation for Hong Kong. The two battalions incorporated these reinforcements in different ways: 1st Winnipeg Grenadiers created a fifth ('E') company, while 1st RRC added a fourth platoon to each of its four existing companies.



BG-BRHK09

# 1st Battalion, The Royal Rifles Of Canada

Lieutenant Colonel WJ Home

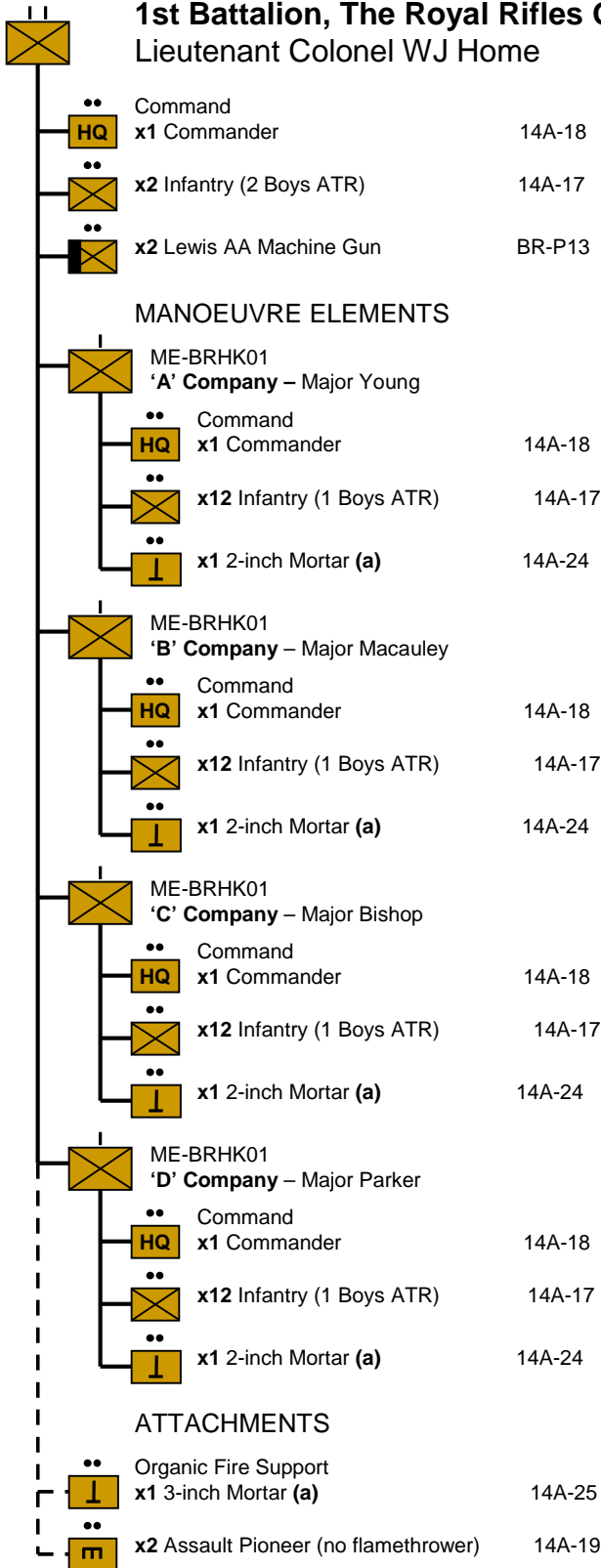

(a) There was already a shortage of mortar ammunition in the garrison armouries, even before the Canadians of 'C' Force arrived in Hong Kong. To add to the problems, the Canadians had been embarked with no mortar ammunition, having been ordered to draw their ammunition from the garrison. After the Canadian arrival the garrison was down to just seventy rounds for each 3-inch Mortar and far fewer for each 2-inch Mortar. The Canadian motor transport, including Carriers, ended up in the Phillipines, where it was used by US and Filipino forces.

(b) 'C' Force received its first-wave of reinforcements before embarkation for Hong Kong. The two battalions incorporated these reinforcements in different ways: 1st Winnipeg Grenadiers created a fifth ('E') company, while 1st RRC added a fourth platoon to each of its four existing companies.



# Hong Kong Volunteer Defence Corps (a)

(Continued on next slide)

## MANOEUVRE ELEMENTS

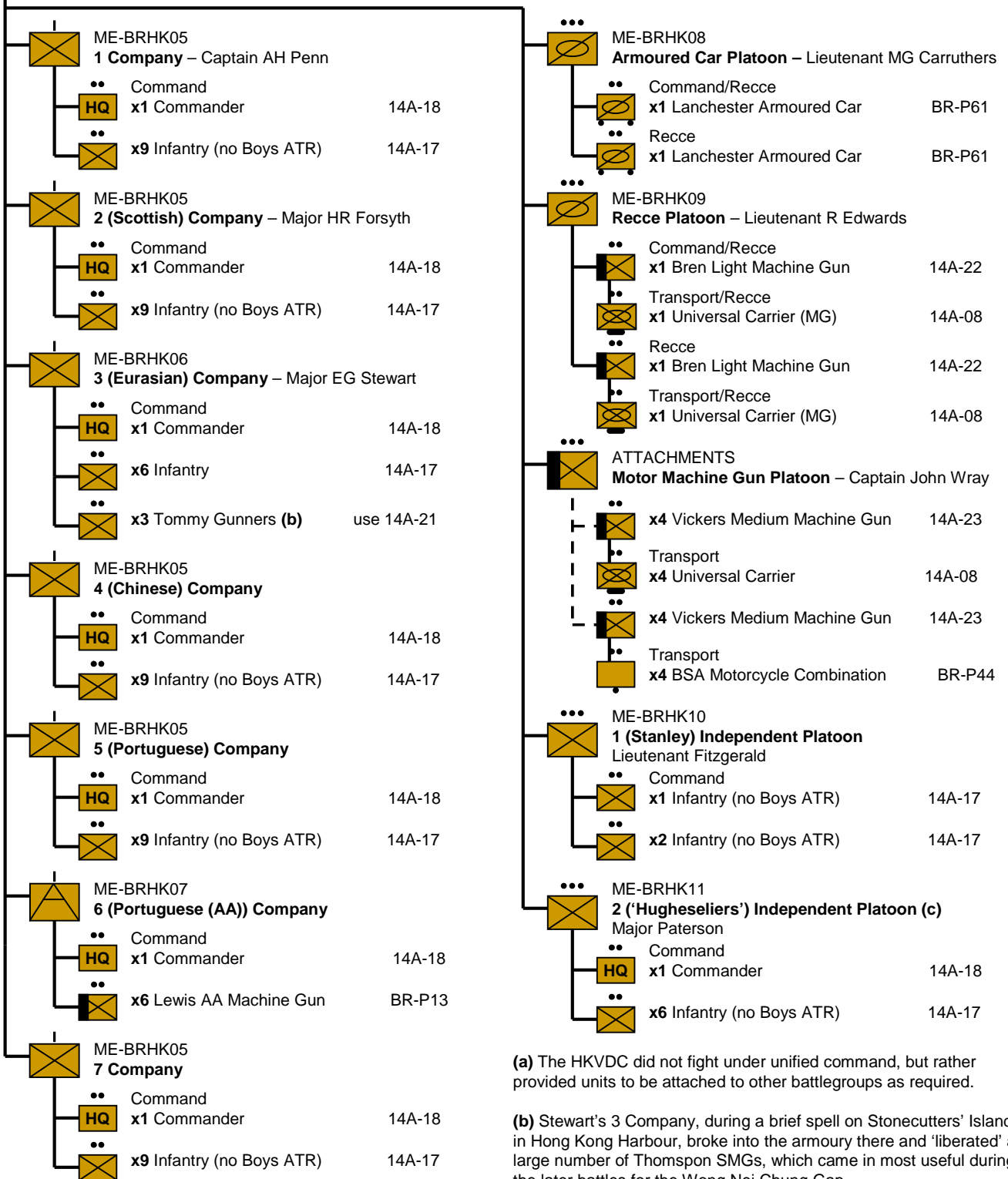

(a) The HKVDC did not fight under unified command, but rather provided units to be attached to other battlegroups as required.

(b) Stewart's 3 Company, during a brief spell on Stonecutters' Island in Hong Kong Harbour, broke into the armoury there and 'liberated' a large number of Thomson SMGs, which came in most useful during the later battles for the Wong Nei Chung Gap.

(c) The 'Hughseliers' were a unit of WWI veterans formed by one Colonel Hughes. A further nickname for them was 'Methuseliers' owing to their advanced years! Nevertheless, the Hughseliers fought tenaciously at Victoria Power Station and held it to the last man.



# Hong Kong Volunteer Defence Corps

(Continued from previous slide)

## MANOEUVRE ELEMENTS

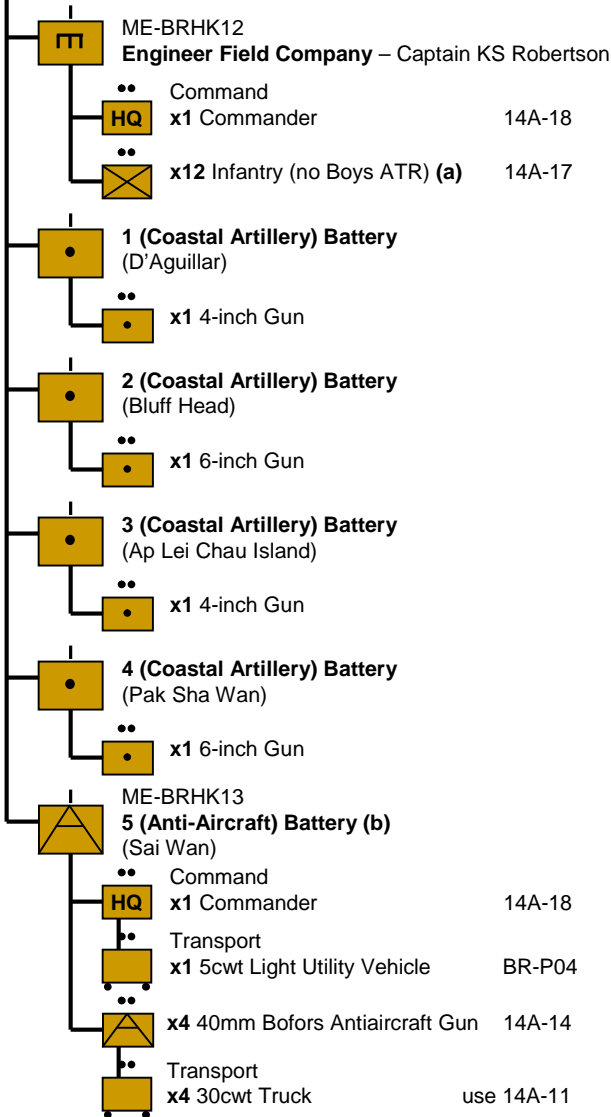

(a) May conduct engineering tasks.

(b) This unit is somewhat conjectural. All I know is that it was mobile and had 'guns' rather than MGs (one gun is recorded as being knocked out by Japanese artillery fire). I don't know what type, nor how many guns it had, so feel free to make your own guesses!

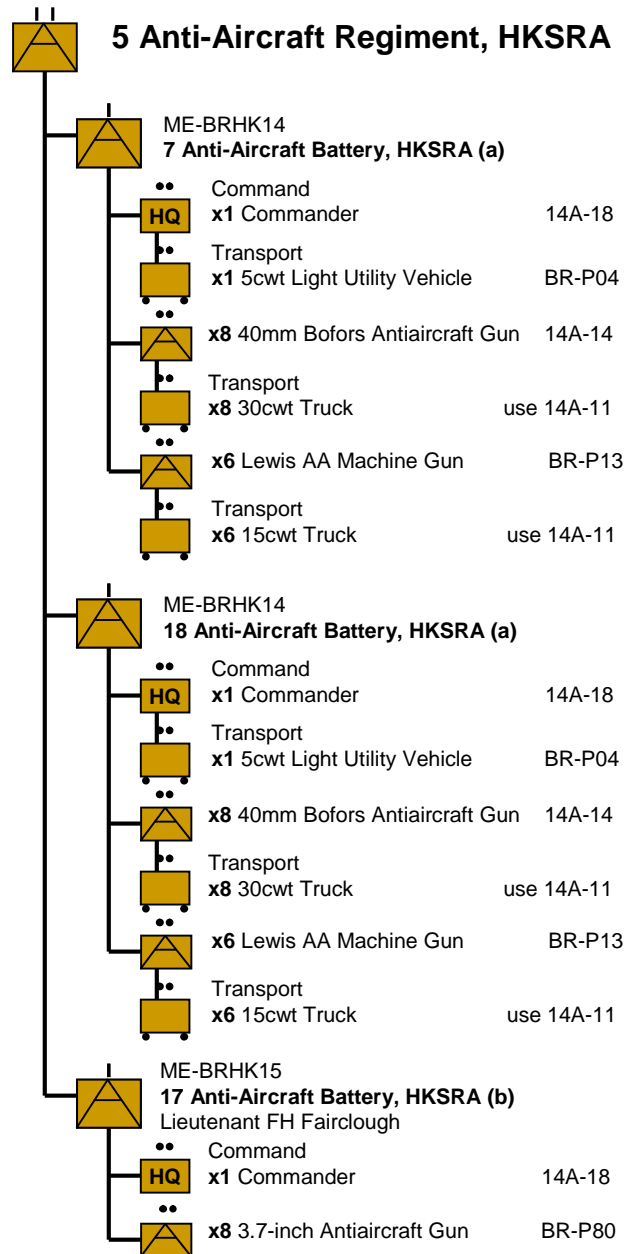
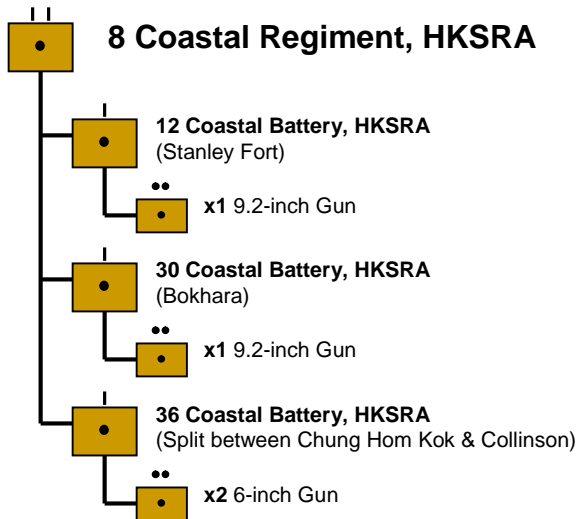

(a) These battery organisations are largely conjectural. They certainly had Bofors and Lewis Guns, though some Bofors guns may have been fixed rather than mobile. There were three troops per battery.

(b) This battery had four troops. It seems to have been fixed rather than mobile.

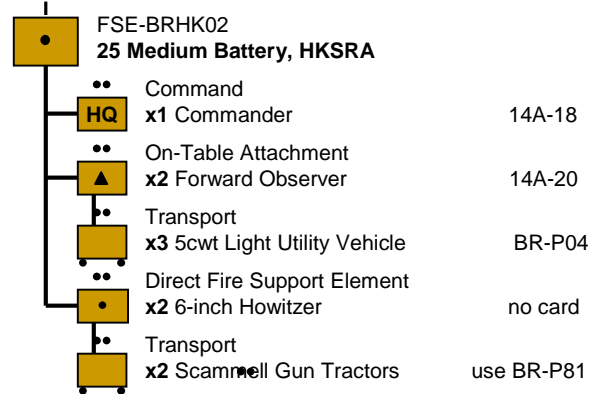
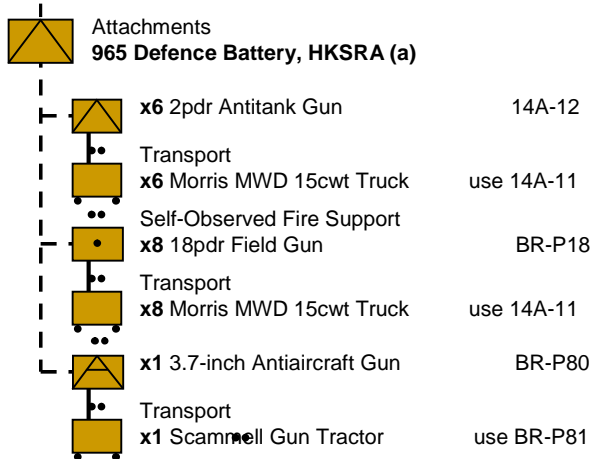
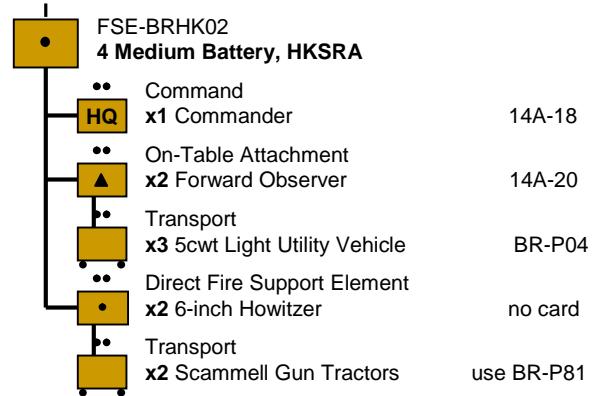
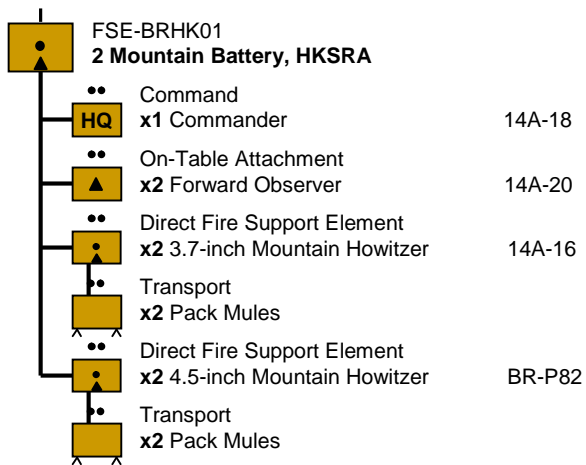
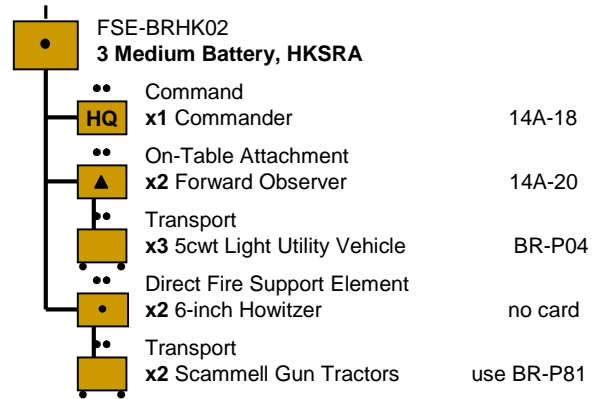
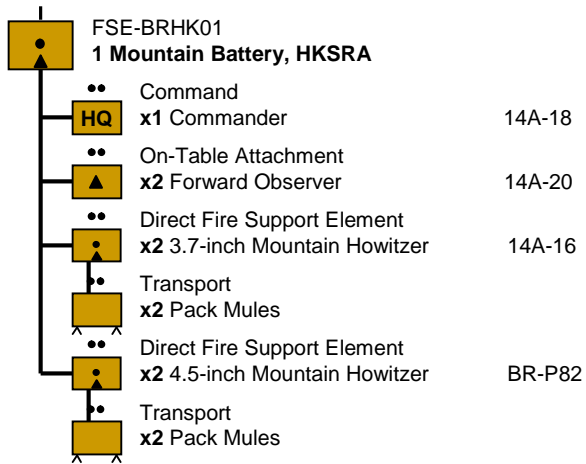

(a) 965 Battery was an independent unit, divided into three troops, designed to engage landing craft on the beaches. One troop of x2 2pdrs and x2 18pdrs was deployed in the south at Stanley. Another troop was deployed in the north-west of the island and also had the 3.7-inch AA detachment. The remaining troop was deployed in the north of the island and also included an extra two detachments of 18pdrs (WWI-era Mk Is, normally used for ceremonial duties). Some of these northern 18pdrs were placed inside pillboxes. In game terms, 965 Battery is deployed as direct attachments to other units. Note that the 18pdrs do not have FOs and may therefore only engage targets within line-of-sight (though may engage them indirectly).

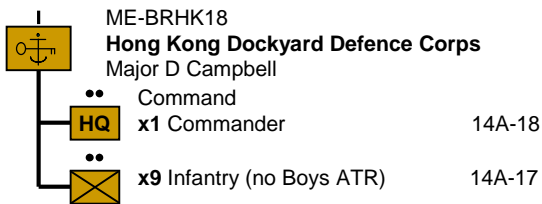
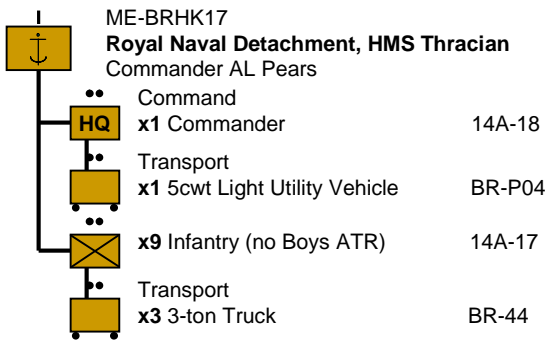
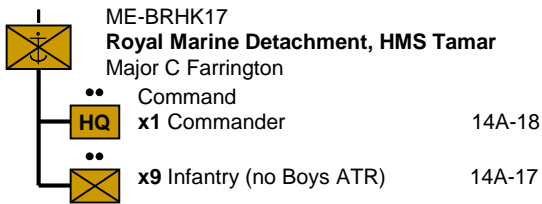
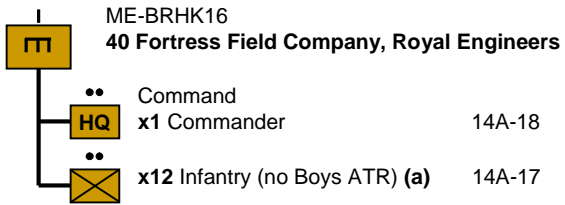
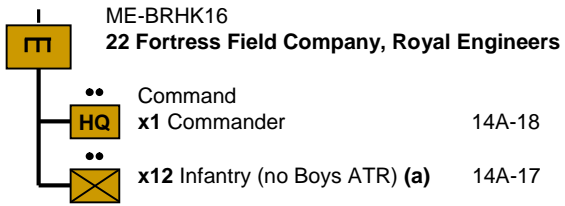

# **Unit Qualities**

## **Experienced**

1st Middlesex  
1, 2 & 3 Companies, HKVDC  
Armoured Car & Recce Platoons, HKVDC

## **Trained**

2nd Royal Scots (on Hong Kong Island)  
2/14th Punjab  
5/7th Rajput  
1st Winnipeg Grenadiers  
1st Royal Rifles Of Canada  
All elements of HKVDC not mentioned elsewhere  
HKSRA Batteries  
Royal Marines  
Royal Engineers

## **Raw**

2nd Royal Scots (on Mainland)  
'E' Company, 1st Winnipeg Grenadiers  
4, 5, 6 & 7 Companies, HKVDC  
Royal Naval Detachment  
HKDDC